



High Pressure Equipment

Pressure Vessels and Reactors

High Pressure Equipment Company designs and manufactures a broad range of pressure vessels and reactors for both bench-scale and pilot plant applications. We have over 250 standard reactor designs which address varied size, material, pressure and temperature requirements.

There are many applications that demand ASME approval for work involving pressure vessels. To satisfy this need, HiP produces a variety of pressure vessels and reactors that meet the requirements of the ASME Pressure Vessel Code.

Complementing our standard product offering is our capability to provide a custom reactor designed to meet your specific needs. Our engineering and technical support will help you identify the specific options you need, ranging from exotic materials to unusual sizes and connections, and then incorporate the appropriate approvals, including ASME.









Index	Page
Pressure Vessel Selection . . .	10.2-10.3
O-Ring Seal Reactors	
Series OC	10.4
Confined Gasket Closure Reactors - Series GC	10.5
Bolted Closure Reactors	10.6
Clover Leaf Reactors	10.7
O-Ring Closure Reactors	
Series R	10.8-10.9
Tubular Reactors	
Series TOC	10.10-10.11
Micro Reactors	
Series MS	10.12

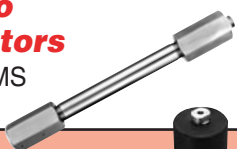

High Pressure Equipment

Reactor Selection Guide

Reactor Design	Description	Standard Material	Maximum Temperature (degrees F)	Maximum Working Pressure (psi)	Standard Capacity
O-ring Seal Series OC 	Simple closure design allows for easy assembly/disassembly and reliable operation. Series OC are economical reactors ideal for low temperature gas or liquid service.	316SS	250	16,000	125 mL to 6,750 mL
Confined Gasket Closure Series GC 	Series GC is designed for studying high temperature and pressure reactions. The vessels utilize thrust bolts and a thrust ring to ensure positive seating of the gasket.	316SS	800	16,000	125 mL to 6,750 mL
Bolted Closure Series BC 	These versatile reactors are the standard of the industry for applications involving moderate pressure ranges. Standard O-rings may be used in place of the metal gasket for lower temperatures.	316SS	650	5,000	300 mL to 2 gal.
Clover Leaf Series CL 	Quick opening cover design needs only one-eighth of a turn rotation for sealing. Ideal for high pressure operations requiring repetitive opening/closing.	4340 alloy steel	250	30,000	1,000 mL to 3,700 mL
O-ring Closure Series R 	Designed for extremely high pressure/low temperature operation, series R reactors feature a threaded closure for easy assembly and disassembly.	4340 alloy steel	250	150,000	77 mL to 30 liters
Micro Reactors Series MS 	Series MS are fixed bed tubular reactors designed for a variety of applications such as small volume testing of components and miniature scale reaction tests.	316SS	800	30,000	2 mL to 64 mL
Tubular Reactors Series TOC 	This line of economical and versatile reactors satisfy many moderate pressure applications. Accumulators can be customized through a variety of options including piston separators.	304SS	O-ring 250 confined gasket 800	10,000	50 mL to 15 liters
Custom Reactors	HiP makes every reactor to order, allowing for economical and timely customizing. We offer a broad range of exotic metals, sizes and connections to meet virtually any requirement.	—	—	—	—

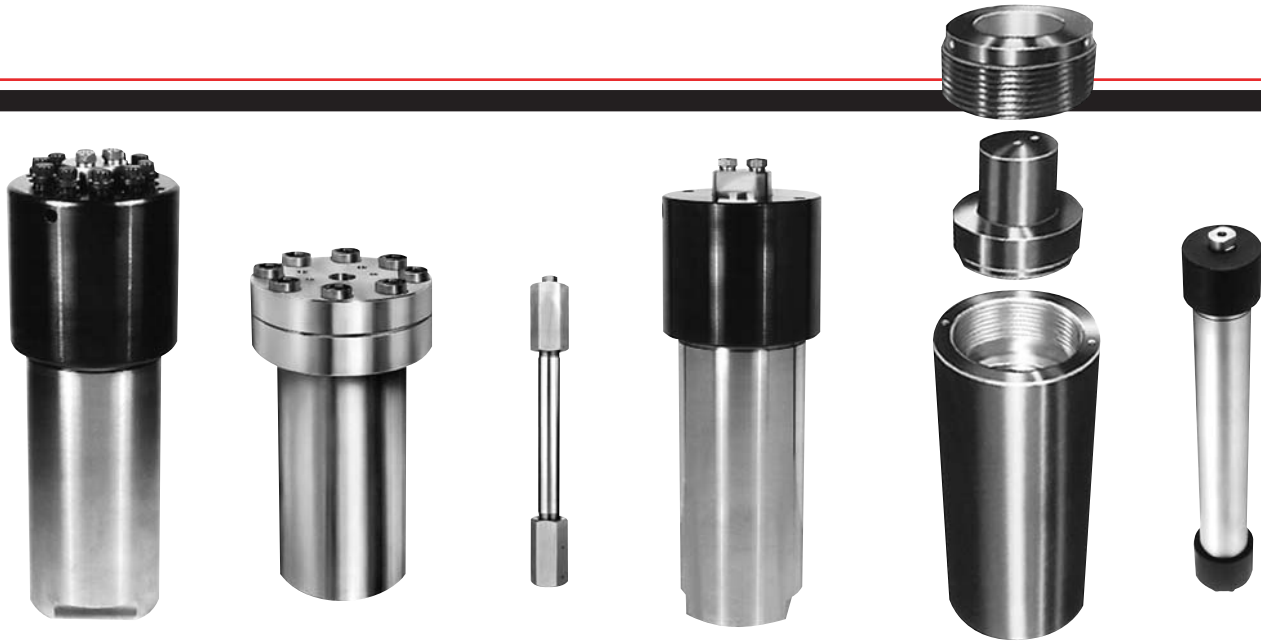

Pressure Vessel Volume Table (cubic inches)

Inside Depth (inches)	Inside Diameter (inches)												
	1/2"	1"	1 1/2"	2"	2 1/2"	3"	4"	5"	6"	7"	8"	9"	10"
4"	0.7856	3.142	7.068	12.57	19.63	28.27	50.26	78.54	113.1	153.9	201.1	254.5	314.2
6"	1.178	4.712	10.60	18.85	29.45	42.41	75.40	117.8	169.6	230.9	301.6	381.7	471.2
8"	1.571	6.283	14.14	25.13	39.27	56.55	100.5	157.1	226.2	307.9	402.1	508.9	628.4
10"	1.964	7.854	17.67	31.42	49.09	70.69	125.7	196.3	282.7	384.8	502.6	636.2	785.2
12"	2.357	9.425	21.21	37.70	58.90	84.82	150.8	235.6	339.3	461.8	603.2	763.4	942.4
14"	2.749	11.00	24.74	43.98	68.72	98.96	175.9	274.9	395.8	538.8	703.7	890.6	1100
16"	3.142	12.57	28.27	50.27	78.54	113.1	201.1	314.2	452.4	615.8	804.2	1018	1257
18"	3.535	14.14	31.81	56.55	88.36	127.2	226.2	353.4	508.9	692.7	904.8	1145	1415
20"	3.928	15.71	35.34	62.83	98.17	141.4	251.3	392.7	565.5	769.7	1005	1272	1571
22"	4.231	17.28	38.88	69.12	108.0	155.5	276.5	432.0	622.0	846.7	1106	1400	1728
24"	4.714	18.85	42.41	75.40	117.8	169.6	301.6	471.2	678.6	923.6	1206	1527	1885
26"	5.106	20.42	45.94	81.68	127.6	183.8	326.7	510.5	735.1	1001	1307	1654	2042
28"	5.499	21.99	49.48	87.96	137.4	197.9	351.8	549.8	791.7	1078	1407	1781	2199

Volume Equivalents

1 in³ = 16.39 mL
 1 mL = 0.061 in³
 1 gal = 231 in³ = 0.134 ft³
 1 ft³ = 1728 in³ = 7.481 gal
 1 L = 61.02 in³ = 0.264 gal

Pressure Conversions

	psi	atm	kg/cm ²
psi	1	0.068	0.070
atm	14.696	1	1.033
kg/cm ²	14.224	0.968	1



High Pressure Equipment

OC Series O-Ring Seal Reactors

The OC Series provide a simple closure that is reliable and easy to assemble and disassemble. Standard material for the body and cover is Type 316 stainless steel. The standard O-ring material is BUNA-N. Temperature is limited by the O-ring to 250°F.

These reactors are suitable for either gas or liquid service. Capacities range from 125 mL to 6,750 mL.

Standard connections are for 1/4" O.D. high pressure (coned and threaded) tubing (HF4). Models OC-1 and OC-3 have one connection in the cover. All other models have two connections in the cover. Contact factory if other connections and/or locations are preferred.

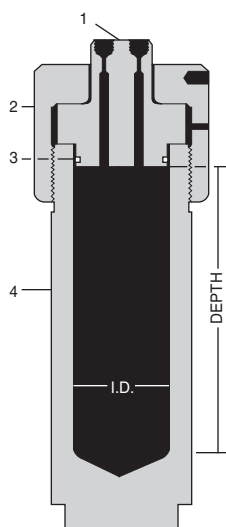

1. COVER
2. CAP
3. "O" RING
4. BODY

316 S.S.
ALLOY STEEL
BUNA-N
316 S.S.

Series OC Reactors

Catalog No.	I.D.	O.D.	Inside Depth	Capacity	Material	Working Pressure psi
OC-1*	1"	2 1/2"	10"	125 mL	316 S.S.	13,800
OC-3*	1 1/2"	2 1/2"	10"	280 mL	316 S.S.	7,750
OC-5	1 1/2"	4 3/8"	10"	280 mL	316 S.S.	16,000
OC-7	1 1/2"	4 3/8"	21"	600 mL	316 S.S.	16,000
OC-9	2"	4 3/8"	10"	500 mL	316 S.S.	12,500
OC-11	2"	4 3/8"	21"	1,040 mL	316 S.S.	12,500
OC-13	2 1/2"	4 3/8"	10"	800 mL	316 S.S.	9,200
OC-15	2 1/2"	4 3/8"	21"	1,160 mL	316 S.S.	9,200
OC-17	3"	6 7/8"	10"	1,150 mL	316 S.S.	13,000
OC-19	3"	6 7/8"	21"	2,430 mL	316 S.S.	13,000
OC-21	3 1/2"	6 7/8"	10"	1,575 mL	316 S.S.	10,500
OC-23	3 1/2"	6 7/8"	21"	3,300 mL	316 S.S.	10,500
OC-25	4"	6 7/8"	10"	2,060 mL	316 S.S.	8,500
OC-27	4"	6 7/8"	21"	4,325 mL	316 S.S.	8,500
OC-29	4 1/2"	6 7/8"	10"	2,600 mL	316 S.S.	6,500
OC-31	4 1/2"	6 7/8"	21"	5,475 mL	316 S.S.	6,500
OC-33	5"	6 7/8"	10"	3,200 mL	316 S.S.	5,000
OC-35	5"	6 7/8"	21"	6,750 mL	316 S.S.	5,000

* One (1) opening only in cover

Confined Gasket Closure Reactors

The Confined Gasket Closure reactors listed below are ideally suited for use at elevated temperatures and pressures as shown in the chart. Thrust bolts with a hardened thrust ring are supplied to insure positive seating of the gasket. Torque required on thrust bolts will range from 70 to 125 foot pounds, depending upon size of reactor, pressure, temperature and media being pressurized. Torquing of bolts should be done in a crisscross staggered pattern to insure uniform seating. A commercial high temperature lubricant should always be applied to the bolt threads and outside cap threads to facilitate removal of the closure.

Standard material for the body, cover and gasket is Type 316 stainless steel. These reactors are suitable for either gas or liquid service and capacities range from 125mL to 6,750 mL.

Standard connections supplied are for 1/4" O.D. high pressure (coned and threaded) tubing (HF4). Models GC-1 and GC-3 have one connection in the cover. All other models have two connections in the cover and a thermowell that extends two-thirds of the inside depth.

Included with each reactor are eye bolts for lifting and necessary collars and glands for the connections. Vise flats are machined on to the bottom of the body for securing while assembling or disassembling closure.



Series GC Reactors

Catalog No.	I.D.	O.D.	Inside Depth	Capacity	Material	Working Pressure (psi)		
						100°F	650°F	800°F
GC-1	1"	2 1/2"	10"	125 mL	316 S.S.	13,800	12,500	12,000
GC-3	1 1/2"	2 1/2"	10"	280 mL	316 S.S.	7,750	7,000	6,900
GC-5	1 1/2"	4 3/8"	10"	280 mL	316 S.S.	16,000	14,500	14,000
GC-7	1 1/2"	4 3/8"	21"	600 mL	316 S.S.	16,000	14,500	14,000
GC-9	2"	4 3/8"	10"	500 mL	316 S.S.	12,500	11,400	11,000
GC-11	2"	4 3/8"	21"	1,040 mL	316 S.S.	12,500	11,400	11,000
GC-13	2 1/2"	4 3/8"	10"	800 mL	316 S.S.	9,200	8,400	8,200
GC-15	2 1/2"	4 3/8"	21"	1,160 mL	316 S.S.	9,200	8,400	8,200
GC-17	3"	6 7/8"	10"	1,150 mL	316 S.S.	13,000	11,000	10,000
GC-19	3"	6 7/8"	21"	2,430 mL	316 S.S.	13,000	11,000	10,000
GC-21	3 1/2"	6 7/8"	10"	1,575 mL	316 S.S.	10,500	9,000	8,000
GC-23	3 1/2"	6 7/8"	21"	3,300 mL	316 S.S.	10,500	9,000	8,000
GC-25	4"	6 7/8"	10"	2,060 mL	316 S.S.	8,500	7,300	6,500
GC-27	4"	6 7/8"	21"	4,325 mL	316 S.S.	8,500	7,300	6,500
GC-29	4 1/2"	6 7/8"	10"	2,600 mL	316 S.S.	6,500	5,500	5,000
GC-31	4 1/2"	6 7/8"	21"	5,475 mL	316 S.S.	6,500	5,500	5,000
GC-33	5"	6 7/8"	10"	3,200 mL	316 S.S.	5,000	4,300	4,000
GC-35	5"	6 7/8"	21"	6,750 mL	316 S.S.	5,000	4,300	4,000

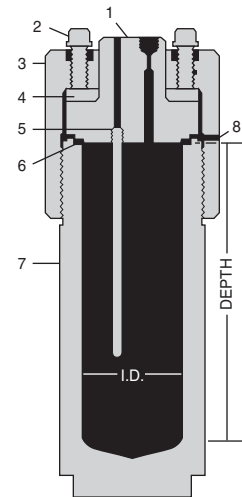

- | | |
|----------------|------------|
| 1. COVER | 316 S.S. |
| 2. SET SCREW | COMM. |
| 3. CAP | ALLOY ST'L |
| 4. THRUST RING | TOOL ST'L |
| 5. GASKET | COPPER |
| 6. GASKET | 316 S.S. |
| 7. BODY | 316 S.S. |
| 8. WEEP HOLE | |



High Pressure Equipment



Bolted Closure Reactors

The Bolted Closure Reactors are designed for use up to 650°F (343°C) at the working pressures indicated. Standard material for the body, cover and gasket is Type 316 stainless steel. Standard O-rings may be used in place of the metal gasket when temperatures permit.

Standard connections include two high pressure (coned and threaded) tubing connections for 1/4" O.D. tubing (HF4) located in the cover. Contact factory if other connections and/or locations are preferred.

Other items available include:

- Heating mantle. Removable quartz fabric cylinder column type. 110 volt, single phase. Bolted closure reactors are supplied with mounting bolt holes on the bottom surface.
- Thermowell for use with 1/16" thermocouple
- Safety head located in side flange with rupture disc (see Page 3.7)

1. PRESSURE CONNECTION (2)
2. SOCKET CAP SCREW
3. COVER
4. GASKET
5. MAIN SEAL
6. BODY
7. THERMOCOUPLE WELL*
8. SAFETY HEAD*

* SUPPLIED AS EXTRA WHEN SPECIFIED

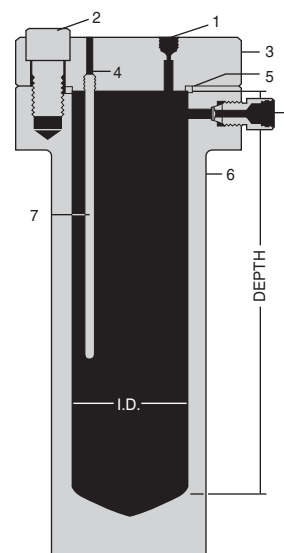

Bolted Closure Reactors

Catalog No.	Capacity	Working Pressure psi	Temperature Rating °F	Inside Diameter	Inside Depth	Approx. Weight (pounds)	Approx. Torque (ft-lb) per Bolt	Material
BC-1	300 mL	5,000	650	2"	6"	21	40	316 S.S.
BC-2	1 liter	5,000	650	3"	9"	50	75	316 S.S.
BC-3	2 liter	5,000	650	3 1/2"	12 1/2"	68	105	316 S.S.
BC-4	1 gallon	3,000	650	5"	12"	97	105	316 S.S.
BC-5	1 gallon	5,000	650	5"	12"	152	175	316 S.S.
BC-6	2 gallon	3,000	650	6 1/2"	14"	245	140	316 S.S.

Clover Leaf Reactors

The "Clover Leaf" Closure Reactors provide maximum ease for quick opening or closing of the cover. The cover is simply inserted into the body and then rotated one-eighth of a turn. A safety locking pin is provided to insure that the cover is properly positioned and locked.

Standard material of construction for these reactors is heat treated 4340 alloy steel. Standard connections include two high pressure (coned and threaded) $\frac{1}{4}$ " O.D. tubing connections (HF4).

Mounting holes are provided in the top and bottom of the body for securing or lifting.



1. LOCK PIN
2. COVER
3. O-RING
4. BODY

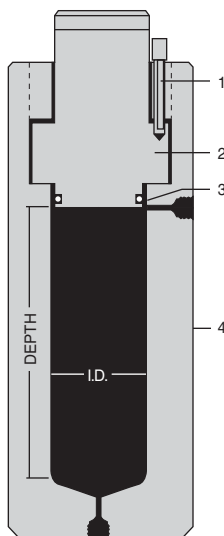

Clover Leaf Closure Reactors

Catalog No.	Inside Diameter	Outside Diameter	Inside Depth	Working Pressure psi	Temperature Rating °F	Capacity	Material
CL-1	3"	6 $\frac{1}{2}$ "	9"	30,000	250	1,000 mL	Alloy Steel
CL-2			18"			2,000 mL	
CL-3			22"			2,500 mL	
CL-8	4"	9 $\frac{1}{2}$ "	9"	30,000	250	1,850 mL	Alloy Steel
CL-9			18"			3,700 mL	



High Pressure Equipment

Series "R" Reactors O-Ring Closure

The Series "R" O-ring Closure Reactors are easily assembled and disassembled with minimal torque required for complete engagement.

Material of construction for standard models is Type 4340 alloy steel (or equivalent) properly heat treated for use at elevated pressures. (Some models can be provided in stainless steel construction at reduced pressures — consult factory).

Sealing is accomplished by a highly reliable combination of O-ring and separate metal back-up ring. The wedge shaped back-up ring is designed to expand and contract as pressure increases or decreases. Consequently, the O-ring is continuously confined with no clearance for extrusion. Minimal initial torque is required to effect a positive seal.

Temperature on these vessels must be restricted to 250°F maximum, due to the BUNA-N (nitrile) O-ring.

(continued on page 10.9)



O-Ring Closure Reactors (one piece cover)

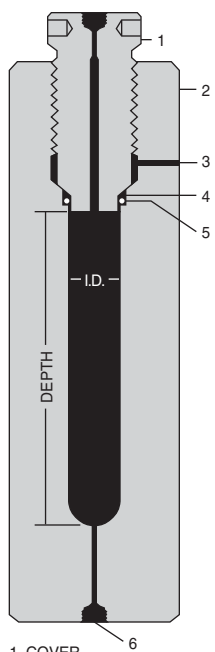

1. COVER
2. BODY
3. VENT HOLE
4. BACK UP RING
5. "O" RING
6. PRESSURE CONNECTION

I.D.	O.D.	Pressure Rating psi	Material	Inside Depth					
				6"	10"	12"	16"	20"	24"
1"	3 ⁵ / ₈ "	30,000	4340 Alloy Steel or equivalent	R1-6-30	R1-10-30	R1-12-30	R1-16-30		
	3 ¹ / ₂ "	40,000		R1-6-40	R1-10-40	R1-12-40	R1-16-40		
	4 ¹ / ₄ "	60,000		R1-6-60	R1-10-60	R1-12-60	R1-16-60		
	5 ¹ / ₂ "	100,000		R1-6-100	R1-10-100	R1-12-100	R1-16-100		
	6 ³ / ₄ "	150,000		R1-6-150	R1-10-150	R1-12-150	R1-16-150		
1 ¹ / ₂ "	3 ⁵ / ₈ "	20,000	4340 Alloy Steel or equivalent	R1.5-6-20	R1.5-10-20	R1.5-12-20	R1.5-16-20		
	4 ¹ / ₈ "	30,000		R1.5-6-30	R1.5-10-30	R1.5-12-30	R1.5-16-30		
	4 ³ / ₄ "	40,000		R1.5-6-40	R1.5-10-40	R1.5-12-40	R1.5-16-40		
	6 ¹ / ₂ "	60,000		R1.5-6-60	R1.5-10-60	R1.5-12-60	R1.5-16-60		
	8"	100,000		R1.5-6-100	R1.5-10-100	R1.5-12-100	R1.5-16-100		
	10 ¹ / ₂ "	150,000		R1.5-6-150	R1.5-10-150	R1.5-12-150	R1.5-16-150		
2"	4 ¹ / ₄ "	20,000	4340 Alloy Steel or equivalent	R2-6-20	R2-10-20	R2-12-20	R2-16-20	R2-20-20	R2-24-20
	5"	30,000		R2-6-30	R2-10-30	R2-12-30	R2-16-30	R2-20-30	R2-24-30
	6 ¹ / ₂ "	40,000		R2-6-40	R2-10-40	R2-12-40	R2-16-40	R2-20-40	R2-24-40
	8 ¹ / ₂ "	60,000		R2-6-60	R2-10-60	R2-12-60	R2-16-60	R2-20-60	R2-24-60
	12"	100,000		R2-6-100	R2-10-100	R2-12-100	R2-16-100	R2-20-100	R2-24-100



Included with each vessel is a Tony Bar for removal of the cover nut and necessary eye bolt holes for lifting of the body and components. Outer surfaces are blackened to prevent rusting.

Vent holes are provided to prevent pressure build up behind the closure in the event of a worn or damaged seal.

Connections include a top and bottom high pressure coned and threaded 1/4" O.D. (HF4) tubing connection. Other sizes or locations for connections can easily be provided when preferred. Consult factory.

Closures are designed in one-piece (cover) for vessels up to 2" I.D. and two-piece (cover and main nut) for vessels larger than 2" I.D.

O-Ring Closure Reactors (two piece cover)

I.D.	O.D.	Pressure Rating psi	Material	Inside Depth					
				6"	10"	12"	16"	20"	24"
3"	6"	20,000	4340 Alloy Steel or equivalent	R3-6-20	R3-10-20	R3-12-20	R3-16-20	R3-20-20	R3-24-20
	7"	30,000		R3-6-30	R3-10-30	R3-12-30	R3-16-30	R3-20-30	R3-24-30
	8 1/2"	40,000		R3-6-40	R3-10-40	R3-12-40	R3-16-40	R3-20-40	R3-24-40
	11 1/2"	60,000		R3-6-60	R3-10-60	R3-12-60	R3-16-60	R3-20-60	R3-24-60
	15"	100,000		R3-6-100	R3-10-100	R3-12-100	R3-16-100	R3-20-100	R3-24-100
4"	8"	20,000		R4-6-20	R4-10-20	R4-12-20	R4-16-20	R4-20-20	R4-24-20
	9 1/4"	30,000		R4-6-30	R4-10-30	R4-12-30	R4-16-30	R4-20-30	R4-24-30
	11"	40,000		R4-6-40	R4-10-40	R4-12-40	R4-16-40	R4-20-40	R4-24-40
	13"	50,000		R4-6-50	R4-10-50	R4-12-50	R4-16-50	R4-20-50	R4-24-50
	15"	60,000		R4-6-60	R4-10-60	R4-12-60	R4-16-60	R4-20-60	R4-24-60
5"	9 1/4"	20,000		R5-6-20	R5-10-20	R5-12-20	R5-16-20	R5-20-20	R5-24-20
	11 1/4"	30,000		R5-6-30	R5-10-30	R5-12-30	R5-16-30	R5-20-30	R5-24-30
	13 3/4"	40,000		R5-6-40	R5-10-40	R5-12-40	R5-16-40	R5-20-40	R5-24-40
	15 3/4"	50,000		R5-6-50	R5-10-50	R5-12-50	R5-16-50	R5-20-50	R5-24-50
	6"	9 1/2"		10,000	R6-6-10	R6-10-10	R6-12-10	R6-16-10	R6-20-10
11 1/2"		20,000		R6-6-20	R6-10-20	R6-12-20	R6-16-20	R6-20-20	R6-24-20
13 3/4"		30,000		R6-6-30	R6-10-30	R6-12-30	R6-16-30	R6-20-30	R6-24-30
15"		40,000		R6-6-40	R6-10-40	R6-12-40	R6-16-40	R6-20-40	R6-24-40
7"		10 3/4"		10,000	R7-6-10	R7-10-10	R7-12-10	R7-16-10	R7-20-10
	13"	20,000		R7-6-20	R7-10-20	R7-12-20	R7-16-20	R7-20-20	
	15 1/4"	30,000		R7-6-30	R7-10-30	R7-12-30	R7-16-30	R7-20-30	
8"	12 1/2"	10,000		R8-6-10	R8-10-10	R8-12-10	R8-16-10	R8-20-10	
	14 1/4"	20,000		R8-6-20	R8-10-20	R8-12-20	R8-16-20	R8-20-20	
9"	13"	10,000		R9-6-10	R9-10-10	R9-12-10	R9-16-10	R9-20-10	
10"	14 3/4"	10,000		R10-6-10	R10-10-10	R10-12-10	R10-16-10	R10-20-10	

1. PRESSURE CONNECTION
2. MAIN UNIT NUT
3. BODY
4. VENT HOLE
5. COVER
6. BACK UP RING
7. "O" RING

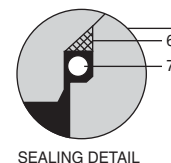
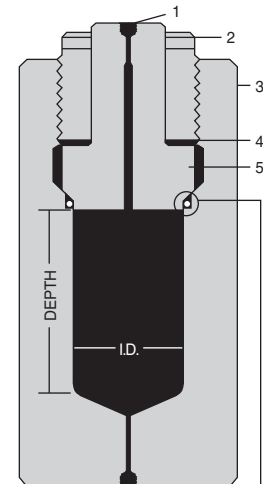



High Pressure Equipment

Tubular Series Reactors

The Tubular Series Reactors are double ended pressure vessels made from commercial quality cold drawn Type 304 stainless steel seamless tubing. Outside (non-wetted) caps are alloy steel. These are both economical and versatile vessels proven in demand for many applications. Finishes are commercial cold drawn finishes, with honed internal finishes.

Standard sizes are shown in the chart on page 10.11, but special lengths and modifications are easily supplied on request. One pressure connection for $\frac{1}{4}$ " O.D. high pressure coned and threaded tubing at each end is standard. Additional end connections are possible on the larger size models. Also, side connections and end cover thermowells can be supplied when required. Consult factory for special requirements.

O-Ring Closures are standard when temperatures do not exceed 250°F. This is an easily assembled closure requiring minimal torque for positive sealing. The standard O-ring material used is BUNA-N (nitrile) with various other O-ring materials available on request.

Confined Gasket Closures are available for temperatures up to 800°F. A 15% reduction in the listed working pressure is required at this elevated temperature level. These closures utilize a metal gasket (304 stainless steel) which can be torqued down for positive sealing. Torque requirements on the thrust bolts will range from 60 to 110 foot pounds depending on size, pressure, temperature and media being pressurized. These confined gasket closures are available for all models except the TOC1 and TOC3 series. When ordering, simply specify catalog number and add suffix "(W/Gasket)".

Piston Separators can be supplied with the O-ring closure vessels for use as compression cylinders. These are ideal for separating a liquid from a gas and other similar applications. The tubing body is supplied with a honed inside diameter surface to accommodate the piston. When ordering, simply specify catalog number and add suffix "(W/Piston)".



Tubular Series Reactors

Tubing Size		Pressure Rating psi	Material	Catalog Number (O-Ring Closure)			
I.D.	O.D.			20"IL	40"IL	60"IL	72"IL
1"	1½"	5,000	Body 304 S.S. Covers 316 S.S.	TOC1-20	TOC1-40	TOC1-60	TOC1-72
¾"	1½"	10,000		TOC3-20	TOC3-40	TOC3-60	TOC3-72
1¼"	2"	6,000		TOC5-20	TOC5-40	TOC5-60	TOC5-72
1"	2"	10,000		TOC7-20	TOC7-40	TOC7-60	TOC7-72
1¾"	2½"	4,000		TOC9-20	TOC9-40	TOC9-60	TOC9-72
1½"	2½"	7,000		TOC11-20	TOC11-40	TOC11-60	TOC11-72
2¼"	3"	3,000		TOC13-20	TOC13-40	TOC13-60	TOC13-72
2"	3"	5,000		TOC15-20	TOC15-40	TOC15-60	TOC15-72
2¾"	3½"	3,000		TOC17-20	TOC17-40	TOC17-60	TOC17-72
2½"	3½"	4,500		TOC19-20	TOC19-40	TOC19-60	TOC19-72
3¼"	4"	2,500		TOC21-20	TOC21-40	TOC21-60	TOC21-72
3"	4"	4,000		TOC23-20	TOC23-40	TOC23-60	TOC23-72
3½"	4½"	3,000		TOC25-20	TOC25-40	TOC25-60	TOC25-72
3"	4½"	5,000		TOC27-20	TOC27-40	TOC27-60	TOC27-72
4"	5"	3,000		TOC29-20	TOC29-40	TOC29-60	TOC29-72
3½"	5"	5,000		TOC31-20	TOC31-40	TOC31-60	TOC31-72

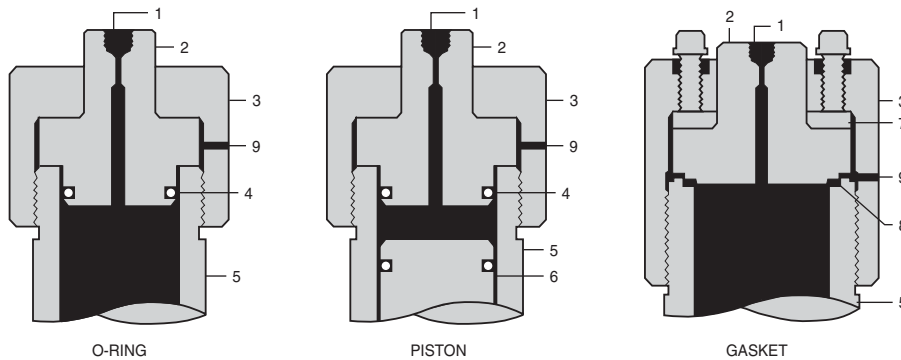
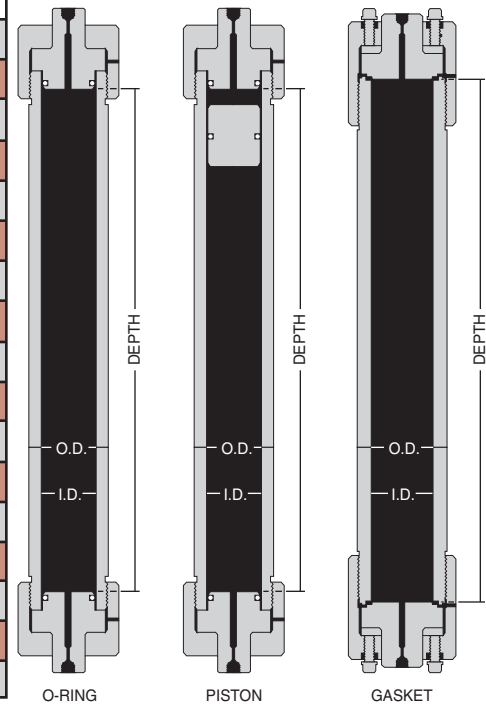

1. PRESSURE CONNECTION
2. COVER
3. CAP
4. "O" RING
5. BODY (BOTH ENDS ALIKE)
6. PISTON
7. THRUST RING
8. GASKET
9. WEEP HOLE

How To Order Tubular Series Reactors

With O-Ring Closure:

Specify catalog number, see ordering table above.

Note: Use of Buna-N O-ring limits maximum working temperature to 250°F. For higher temperatures to 800°F, order gasket closure.

With Piston Separators:

Specify catalog number, see ordering table above and add "(W/Piston)" as suffix.

Because of temperature limitations pistons are not normally ordered in combination with the gasket closure.

With Gasket Closure:

Specify catalog number, see ordering table above and add "(W/Gasket)" as suffix.

* Gasket closure is not available on 1½" O.D. tubing size vessels.

Example:
TOC15-20 (W/Gasket).



High Pressure Equipment

Series "MS" Micro Reactors

The Micro Reactors shown are designed for numerous applications including small volume testing of components and miniature scale reaction tests.

Standard material of construction is Type 316 stainless steel.

Operation at temperatures up to 800°F is made possible by the metal to metal seal construction. Working pressures should be reduced by approximately 15% at the maximum 800°F temperature level.

Connections are for $\frac{1}{4}$ " O.D. high pressure coned and threaded tubing (HF4). One connection is provided at each end. Other sizes or types of connections can be provided. Thermocouples can easily be installed with the use of thermocouple adapters (refer to section 8.0).

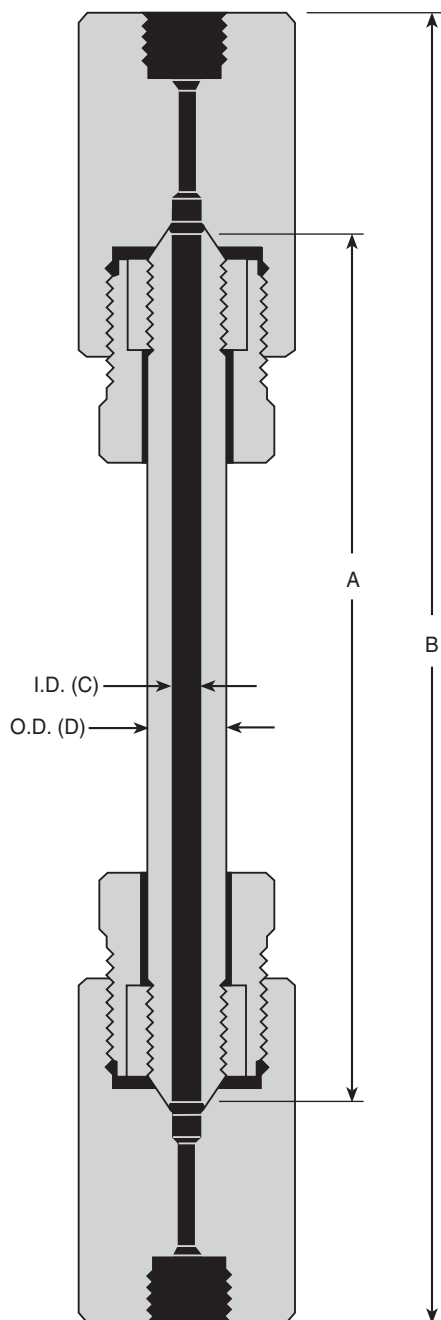

Catalog No.	Capacity	Working Pressure psi	(C) Inside Diameter	(D) Outside Diameter	(A) Inside Depth	(B) Overall Length
MS-1	2 mL	60,000	$\frac{3}{16}$ "	$\frac{9}{16}$ "	4"	7"
MS-2	3 mL				6"	9"
MS-3	4 mL				8"	11"
MS-4	5 mL				10"	13"
MS-5	6 mL				12"	15"
MS-11	5 mL	20,000	$\frac{5}{16}$ "	$\frac{9}{16}$ "	4"	6 $\frac{1}{2}$ "
MS-12	7 $\frac{1}{2}$ mL				6"	8 $\frac{1}{2}$ "
MS-13	10 mL				8"	10 $\frac{1}{2}$ "
MS-14	12 $\frac{1}{2}$ mL				10"	12 $\frac{1}{2}$ "
MS-15	15 mL				12"	14 $\frac{1}{2}$ "
MS-16	24 mL	20,000	$\frac{9}{16}$ "	1"	6"	9"
MS-17	41 mL				10"	13"
MS-18	65 mL				16"	19"
MS-19	81 mL				20"	23"