

Sprague Operation and Maintenance Manual

MODEL S-216-J-() Series AIR-DRIVEN HYDRAULIC PUMP

ISSUED NOVEMBER 1994
Revised October 2014



WARRANTY POLICY

WARRANTY: REMEDIES:

HIGH PRESSURE EQUIPMENT, SPRAGUE PRODUCTS, GUARANTEES ITS GOODS TO BE FREE FROM DEFECTS IN WORKMANSHIP OR MATERIAL FOR A PERIOD OF ONE (1) YEAR FROM DATE OF SHIPMENT. **THIS WARRANTY DOES NOT INCLUDE:** PACKINGS, SEALS, NOR FAILURES CAUSED BY LACK OF PROPER MAINTENANCE; INCOMPATIBLE FLUIDS; FOREIGN MATERIALS IN THE DRIVING MEDIA OR IN THE PUMPED MEDIA; OR APPLICATION OF PRESSURES, TEMPERATURES, AND CYCLES BEYOND SPECIFICATION OR CATALOG RATINGS.

GOODS BELIEVED TO BE ORIGINALLY DEFECTIVE MAY BE RETURNED BY THE ORIGINAL BUYER, TRANSPORTATION CHARGES PREPAID, ONLY UPON RECEIPT OF A RETURNED MATERIALS AUTHORIZATION NUMBER FROM THE PROPER PERSONNEL AT SPRAGUE. THE RETURN SHOULD INCLUDE THE FOLLOWING: THE ORIGINAL PURCHASE DATE AND ORDER NUMBER, SERIAL NUMBER, MODEL NUMBER, AND OTHER PERTINENT DATA TO ESTABLISH WARRANTY CLAIM, AND TO EXPEDITE THE RETURN OR REPLACEMENT TO THE BUYER.

EXCEPT FOR THE WARRANTIES SPECIFICALLY SET FORTH HEREIN, **THERE SHALL BE NO EXPRESS OR IMPLIED WARRANTIES OF ANY KIND, NOR SHALL THERE BE A WARRANTY OF MERCHANTABILITY WITH RESPECT TO THE GOODS. FURTHERMORE, SPRAGUE MAKES NO WARRANTY THAT THE GOODS ARE FIT FOR ANY PARTICULAR PURPOSE.**

COMPLAINTS REGARDING DEFECTS MUST BE MADE BY BUYER WITHIN ONE (1) YEAR FROM THE DATE OF SHIPMENT. SPRAGUE RESERVES THE RIGHT TO ACT AS SOLE JUDGE IN DETERMINING THE NATURE AND CAUSE OF THE DEFECT AND SHALL DO SO UPON RECEIVING AND INSPECTING THE RETURNED GOODS. **SPRAGUE IS NOT LIABLE FOR UNAUTHORIZED DISASSEMBLY, REPAIR, ALTERATION, AND DEFECTS OR DAMAGE RESULTING FROM MISUSE, NEGLIGENCE OR MISAPPLICATION OF THE GOODS.** IN ADDITION, IT IS EXPRESSLY AGREED BY BUYER, IN PURCHASING THE GOODS THAT THE LIABILITY OF SPRAGUE, IF ANY, SHALL BE LIMITED SOLELY TO THE REPLACEMENT AND REPAIR OF THE GOODS IN ACCORDANCE WITH THE WARRANTIES SPECIFICALLY AND EXPRESSLY SET FORTH HEREIN. THE REMEDIES OF THE BUYER ARE THE EXCLUSIVE AND SOLE REMEDIES AVAILABLE, AND, IN THE EVENT OF A BREACH OR REPUDIATION OF ANY PROVISION OF THIS AGREEMENT BY SPRAGUE, BUYER SHALL NOT BE ENTITLED TO RECEIVE ANY INCIDENTAL DAMAGES AS THAT TERM IS DEFINED IN SECTION 2-715 OF THE UNIFORM COMMERCIAL CODE. BUYER WAIVES THE BENEFIT OF ANY RULE THAT DISCLAIMER OF WARRANTY SHALL BE CONSTRUED AGAINST SPRAGUE, AND AGREES THAT SUCH DISCLAIMERS HEREIN SHALL BE CONSTRUED LIBERALLY IN FAVOR OF SPRAGUE.

TABLE OF CONTENTS

	Page
Warranty Policy.....	2
Terms & Conditions	Back Cover
Section 1.0 Installation.....	4
Section 2.0 Operation.....	4
Section 3.0 Maintenance	5
Section 4.0 Disassembly	5
Section 5.0 Inspection.....	8
Section 6.0 Repair and Replacement.....	8
Section 7.0 Reassembly	9
Section 8.0 Test.....	11
Section 9.0 Illustrated Parts Breakdown (IPB) and Supplemental Data	12

INTRODUCTION

This Handbook provides the necessary information to install, operate service and overhaul the basic hydraulic pump, model S-216-J-().

While other model pumps vary in some details of design from the basic pumps, the installation, operation, maintenance and many of the component parts remain the same or are similar.

Many of the instructions contained in this Handbook are applicable to all hydraulic pump models with J type air valves.

HOW THE SPRAGUE AIR-DRIVEN PUMP WORKS

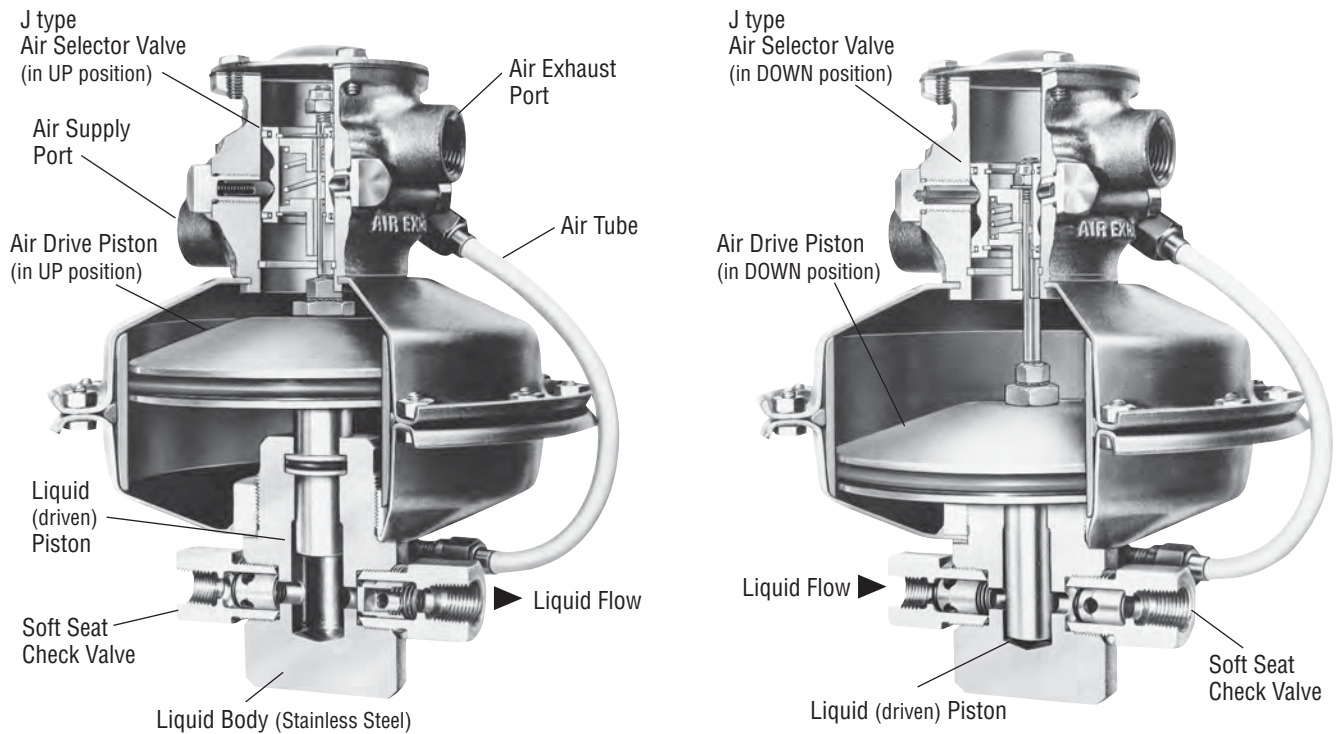

S-216-J() SERIES PUMP

The Sprague Products pump develops high output pressure by applying the principle of differential areas. The pump has a large area air piston, air-driven at low pressures. This air piston drives a small area fluid piston that in turn pumps liquids at high pressures.

The fluid output pressure is determined by the ratio between the area of the air driven piston, the area of the fluid driven piston, and the applied operating air pressure.

The area relationship of the air piston to the fluid piston is referred to as the pump ratio. A nominal ratio is indicated in the dash number which follows the pump model basic number. Actual ratio may differ from nominal ratio.

Example: S-216-J-10 pump has an approximate ratio of 10 to 1 or 10 psi liquid pressure for each 1 psi of operating air pressure.

In operation, an S-216-J-10 pump using 100 psi of input air pressure will produce a maximum liquid output pressure of 1000 psi; 80 psi air will produce an output pressure of 800 psi air; 60 psi air . . . 600 psi output; and 40 psi air . . . 400 psi output.

By regulating the incoming air supply at the pressure regulator, the liquid output pressure can be adjusted through the pump's pressure range.

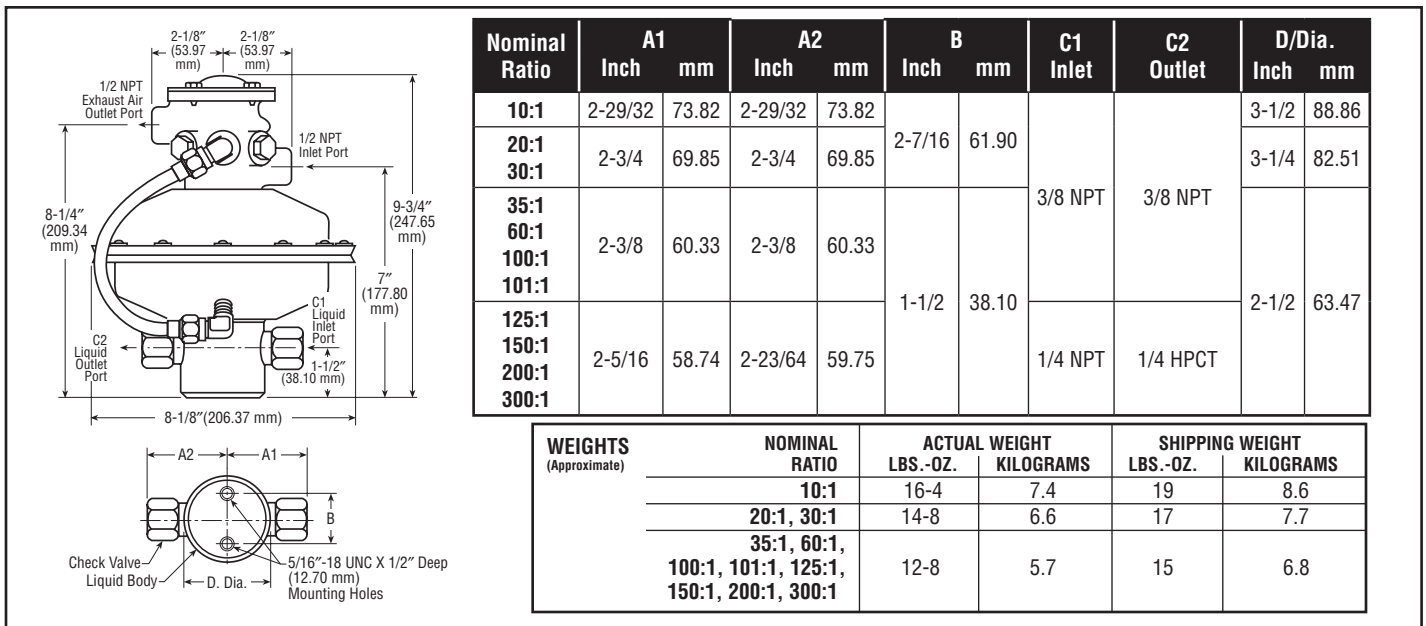

Figure 1-1 Basic pump dimensions and weights

1.0 INSTALLATION

1.1 The S-216 Series pumps require only bolt attachment to a base plate and plumbing connection of three lines:

- From driving air source to pump air inlet port.
- From fluid source to pump fluid inlet port.
- From pump fluid outlet port to working system.

To obtain effective fluid sealing at the inlet and outlet check ports of the pump, the NPT male threads on the two fluid lines connecting to and from the pump should each be sealed with two wraps of Teflon® tape.

Note: Tape to within one or two threads of the end of the fitting, NOT at the end. DO NOT use pipe dope. DO NOT tape the

driving air supply line thread connecting to the pump. No special tools are required to install the pump.

- LOCATION-For maximum performance, the pump's fluid inlet port should be level with or below the fluid reservoir or fluid source.
- MOUNTING-Two mounting holes are provided on the underside of the basic model pump's fluid body for attachment to a base plate or platform. See Figure 1-1.
- PLUMBING-All plumbing must be rated to 1-1/2 times maximum operating pressures.
 - Connect driving air supply line to pump air inlet port.
 - Connect fluid supply line from reservoir to pump inlet check valve.

- Connect system fluid line to pump outlet check valve.
- A muffler may be attached to the pump's air exhaust port.

See Figure 1-2 for:

- Line hook up to pump.
- Pump installation.
- Recommended accessories.

2.0 OPERATION

2.1 START PUMP

- Close air shut-off valve between pump and pressure regulator.
- Turn on driving air supply.
- Adjust air pressure regulator at air control unit (FRL) to 25 psi (1.73 bar) starting pressure.
- Open valve in hydraulic circuit to allow free fluid flow.
- Slowly open the air shut-off valve to start the pump operating.
- After pump has been primed, close valve in hydraulic circuit.
- Check pump and air circuit for leaks in lines, fittings, etc.
- With pump and circuit operating properly, readjust air pressure regulator until desired pump discharge pressure is reached. The hydraulic circuit is ready to operate.

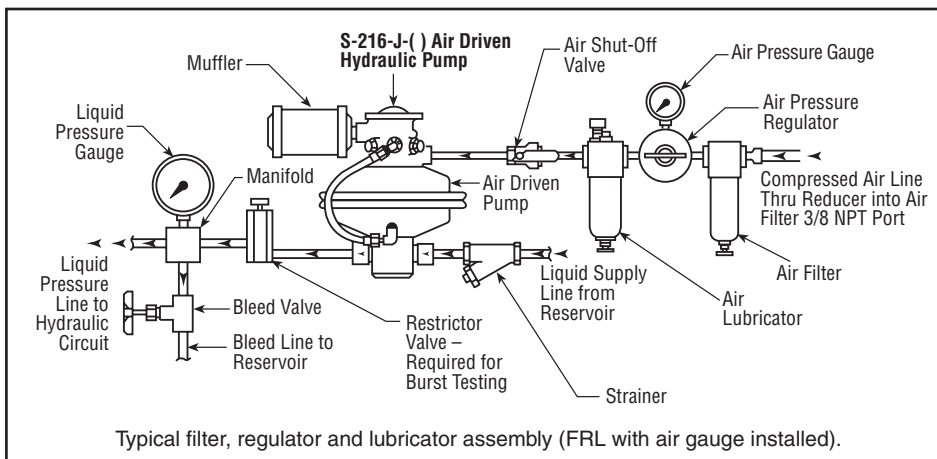

Figure 1-2 Pump installed in typical circuit with recommended accessories which are available from Sprague Products.

WARNING
Do not exceed 100 p.s.i.g. inlet air pressure.

®Teflon is a trademark of the DuPont Company.

2.2 STOP PUMP

- a. Close air shut-off valve. Normally after driving air supply has been adjusted, the pump can be on-off controlled or reduced in pumping rate at the air shut-off valve.
- b. After stopping pump, bleed off hydraulic pressure before disconnecting the hydraulic circuit.

3.0 MAINTENANCE

- 3.1 SPECIAL TOOLS – None is required to service pump. Use standard tools.
- 3.2 INSPECTION and MAINTENANCE –Refer to Chart 3-1 as a guide to general maintenance. Recommended inspection periods may require adjustment to comply with local conditions or as determined by experience.
- 3.3 TROUBLE-SHOOTING – Chart 3-2 aids in checking the pump and outlines corrective action .

To eliminate the unnecessary disassembly of the pump, probable causes of malfunction are listed in the following order:

- a. Causes that can be corrected without disassembly of pump.
- b. Causes that can be corrected with partial disassembly of pump.
- c. Causes that require complete disassembly of pump.

The number in parenthesis following the part name corresponds to the item number on the S-216-J-() Illustrated Parts Breakdown (IPB), pages 12-15.

- 3.4 For disassembly, inspection, repair, and reassembly of S-216-J-() pump, refer to Sections 4.0, 5.0, 6.0 and 7.0.
- 3.5 For IPB, and service and overhaul instructions of other air-driven pumps, refer to supplemental data sheets in this Handbook, Section 9.0.

4.0 DISASSEMBLY

- 4.1 The disassembly procedure describes the removal of the entire upper or “air” assembly of parts from the lower or “liquid” portion of the pump. The number in parenthesis following the part name corresponds to the item number on the S-216-J-() Illustrated Parts Breakdown (IPB), pages 12-15.

When the pump is disassembled, matched parts (i.e. fluid body and fluid piston) should be kept together and handled carefully to avoid damage to lapped or honed surfaces.

To wash metal parts, use any quality commercial solvent that is available.

The pump disassembly and reassembly can be done with the following standard hand tools:

- a. O-ring removal tool
- b. Retainer ring pliers
- c. Ratchet wrench with 7/16” Dia. x 3” extension hex socket
- d. 7/16” wrench
- e. 11/16” wrench
- f. 3/4” wrench
- g. 15” adjustable wrench

Power equipment and special tools can be used at user’s discretion.

- 4.2 Use bench vise to hold pump while disassembling and reassembling. Cushion vise jaws with soft aluminum plates to prevent scratching the fluid body. See Figure 4-1. Position pump in vise with tube (48) to the front of the pump.

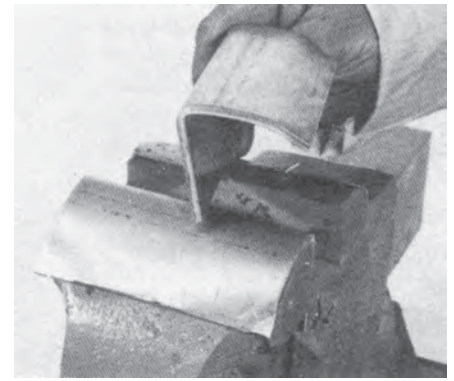

Figure 4-1 Aluminum plates in vise.



Figure 4-2 Removing air valve cover.

ITEM	INSPECTION PERIOD	REQUIRED MAINTENANCE
(1) Driving Air Filter	(a) 10 hours	Check for and drain liquid accumulated in filter from condensation.
	(b) 50 hours	Check filter element and other components for clogging. Clean as required.
(2) Driving Air Lubricator (not required on JN type pumps)	(a) 10 hours	Check oil supply to fill line. Use SAE #10 or equivalent good quality oil. Check oil drip rate (2 drops per minute normal) at adjustment knob.
(3) Driving Air Pressure Regulator.	(a) Periodic	Check for air leaks. Repair as required.
(4) Driving Air Pressure Gauge	(a) 10 hours	Shutoff inlet air pressure and check for zero reading.
	(b) 50 hours	Calibrate against master gauge.
(5) Pump	(a) 10 hours	Check pump and fittings for air or fluid leakage. Repair as required.

Chart 3-1 Schedule of inspection and maintenance.

! WARNING

Before any maintenance or repair is attempted, the compressed air line to the pump should be disconnected, and all air pressure and fluid pressure allowed to bleed from the pump.

TROUBLE	PROBABLE CAUSE	CORRECTION
(1a) PUMP IS NOT DELIVERING FLUID (pump running)	(a) Reservoir fluid supply is low.	Add fluid as required.
	(b) Fluid supply line to pump inlet check valve is clogged.	Remove and clean line. Check reservoir, its inlet filter and outlet for accumulation of foreign matter. Clean as required.
	(c) Foreign matter is lodged in pump inlet and outlet check valves (22 and 31).	Remove and clean check valves. Replace o-rings (24 and 32) on poppets (23 and 33).
(1b) PUMP IS NOT DELIVERING FLUID (pump not running)	(d) Driving air supply is disconnected, air shut-off valve closed or air filter clogged.	Reconnect line. Open valve. Clean air filter.
	(e) Air pressure regulator not adjusted.	Adjust regulator.
	(f) Air shuttle valve (4A) is sticking.	Remove and clean air valve and housing assembly and its shuttle valve components. Adjust air lubricator.
	(g) Connecting rod (37) is improperly adjusted or bent (may occur after pump overhaul).	Readjust rod and nut (44). Refer to paragraph 7.19 and Figure 7-13. Straighten or replace rod.
	(h) Spring (4E) in shuttle valve is broken.	Replace spring.
(2) PRESSURE DROP OR PUMP FAILS TO BUILD-UP DISCHARGE FLOW (pressure)	(a) Leakage or blockage at inlet or outlet check valves (22 or 31). Damaged or worn o-rings.	Remove and clean check valves. Look for foreign matter lodged in seating areas. Replace damaged or worn o-rings.
	(b) Fluid found in lower housing (19), damaged seals in sealing groove of fluid body.	Replace o-rings (17 or 29), packing retainers (18), and back-up rings (18A or 30A).
	(c) Damaged o-ring (15) in outer groove of air piston (14) or scratched or scored cylinder (13). Either or both allow air pressure to escape to exhaust port.	Replace o-ring. Inspect cylinder for scores or scratches. If marred, replace cylinder.
(3) HYDRAULIC FLUID IN EXHAUST AIR	(a) Damaged seals in fluid body (21) or fluid piston (16 or 28) scored.	Replace o-ring (17 or 29) and retainers (18 or 30). Inspect fluid piston for score marks; polish as required. Replace pistons and fluid body if in-service-wear allowance exceeded.
(4) AIR LEAK IN COVER OF AIR VALVE & HOUSING ASSY.	(a) Cover (1) loose. Cracked or damaged o-ring.	Tighten cover bolts (3) or replace o-rings.
(5) AIR IN SYSTEM	(a) Air leak in suction line from reservoir to pump or at pump inlet check valve.	Tighten line fittings; use Teflon® tape to seal fittings.
	(b) Reservoir fluid level below reservoir suction outlet.	Check reservoir fluid level; refill as required.

Chart 3-2 Troubleshooting pump operation.

- 4.3 Unscrew the four cap screws (3) to remove the air valve cover (1) and its O-ring (2). See Figure 4-2.
- 4.4 Remove tube assembly (48) by removing the two fittings from the two 90° elbows on the upper and lower housing. See Figure 4-3. Do not remove elbows. Apply air hose and air pressure to lower 90° elbow to raise air piston (14) and shuttle (4A) to upper position. See Figure 4-4.
- 4.5 Use 7/16" wrench to remove self-locking nut (44) from connecting rod (37). See Figure 4-5.
- 4.6 Use 7/16 socket on ratchet wrench to remove the twelve cap screws (45) and nuts (46) that attach the upper housing (19). See Figure 4-6. Lift and remove the upper housing assembly. Remove stop sleeve (4) from connecting rod.
- 4.7 If the shuttle assembly in the upper housing needs removal and disassembly, proceed as follows:
- 4.7.1 Use 11/16" wrench and remove the four sets of detent bolts (6), springs (7), and pins (9) from the air valve body (5A). See Figure 4-7.
- 4.7.2 From inside the upper housing, push upward on shuttle stop (4F) to remove the shuttle assembly. See Figure 4-8.
- 4.7.3 Using retainer ring pliers, remove the snap ring (4G) to release the flanges (4), spring (4E), and guide sleeve (4) from the shuttle (4A). See Figure 4.9.
- 4.8 Remove the cylinder (13) and its o-ring (15) from the lower housing (19). See Figure 4-10.
- 4.9 Remove rod, air piston (14) and fluid piston (16 or 27) from the fluid body (21). See Figure 4-11.
- 4.10 Disassemble shifting nut (40), lock washer (39), plain nut (38) and connecting rod from air piston (14). See Figure 4-12. Unscrew air piston from fluid piston (16). Remove the o-ring (15) from the air piston.
- Note:** *Disassembly is not necessary unless one of the components is damaged.*

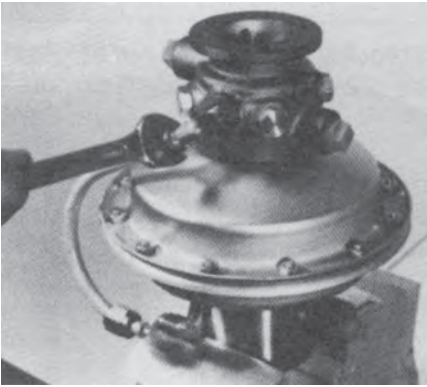

Figure 4-3 Removing tube assembly.

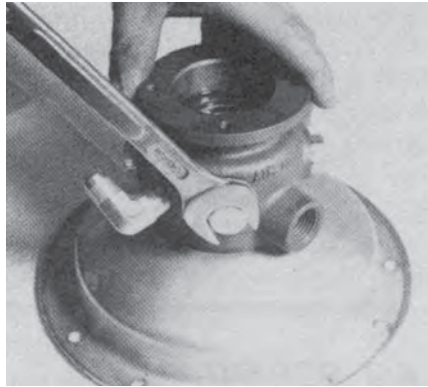

Figure 4-7 Removing detent bolt, spring and pin.

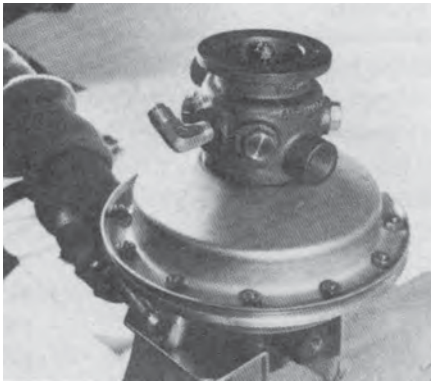

Figure 4-4 Applying air pressure to raise air piston and rod.

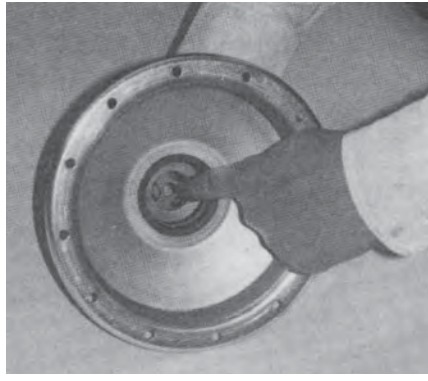

Figure 4-8 Pressing shuttle out of upper housing.

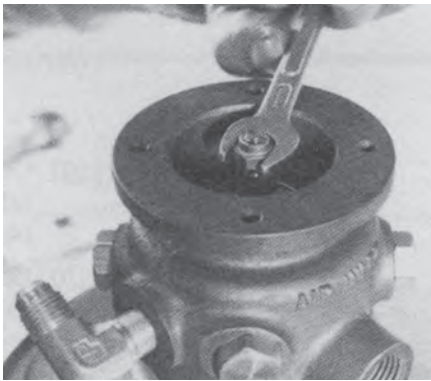

Figure 4-5 Removing self-locking nut from connecting rod.

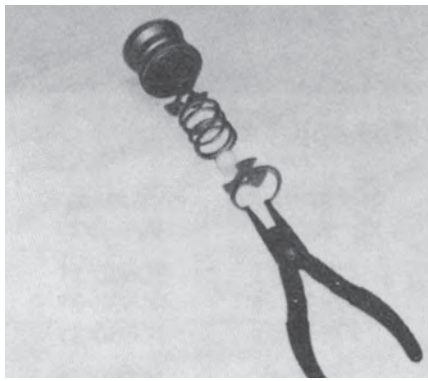

Figure 4-9 Removing shuttle assembly components.

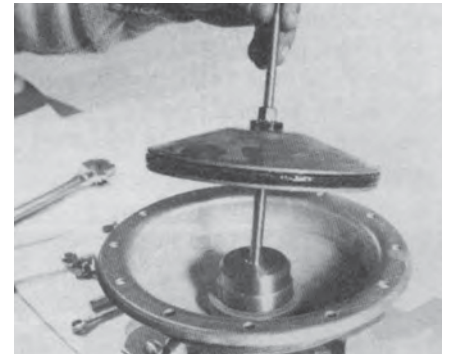

Figure 4-11 Removing air piston and fluid piston from fluid body and lower housing.



Figure 4-6 Removing housing screws and nuts.

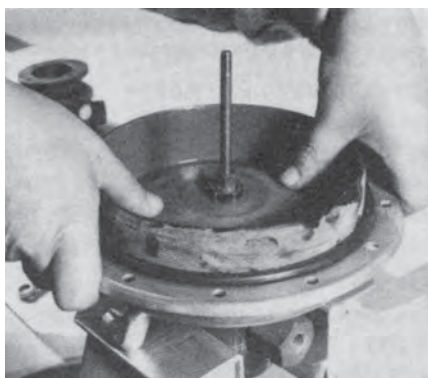

Figure 4-10 Removing cylinder from lower housing.

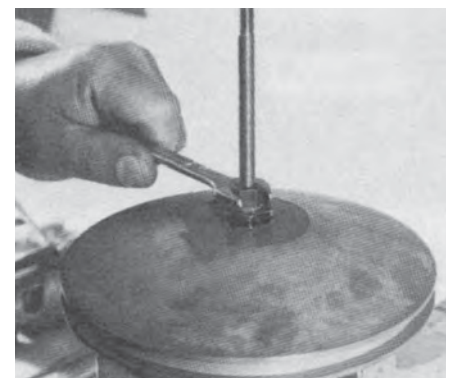

Figure 4-12 Disassembling air piston components.

- 4.11 Using o-ring removal tool, carefully remove the two Teflon[®] retainers (18) and o-ring (17) from the seal groove in the fluid body (21). See Figure 4-13. Discard the old retainers and o-ring. For o-ring removal of JB models, see page 15.
- 4.12 Using adjustable wrench, remove the inlet check valve assembly from the fluid body port. See Figure 4-14. Note the sequence of parts removal and the position of poppet. See Figure 7-2. Wipe surplus fluid from the inside port.
- 4.13 Using adjustable wrench, remove outlet check valve assembly from the fluid body port. Note the sequence of parts removal and position of poppet. Wipe surplus fluid from port.
- 4.14 Check for leakage at gasket (20) junction between the lower housing (19) and the fluid body (21). Unless there is evidence of leakage at gasket (20), **DO NOT** remove the lower housing from the fluid body.

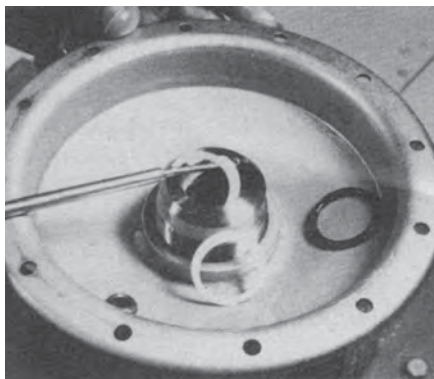

Figure 4-13 Removing retainers and O-ring from fluid body.

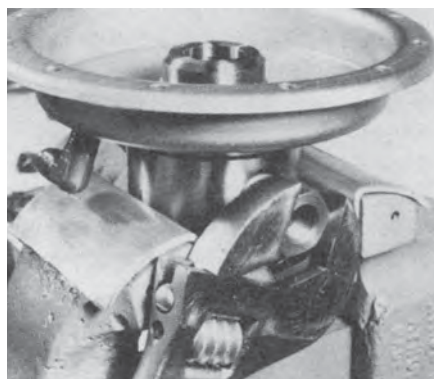

Figure 4-14 Removing check valves from fluid body.

5.0 INSPECTION

- 5.1 Wash all metal parts in solvent. Dry parts thoroughly with air or with lint-free cloth. Remove hardened sediment with a soft bristle brush. Do not scrape parts with a metal tool.
- 5.2 Under a light, and preferably under magnification, visually inspect parts for cracks, pitting, scoring, corrosion or galling.
- 5.3 Inspect all threaded parts for chipped, crossed or stripped threads.
- 5.4 Inspect and measure the free (relaxed) length of springs:
 - a. Detent springs (8), 7/8 inches (22.23 mm);
 - b. Check valve springs (25), 3/4 inches (19.05 mm);
 - c. Check valve springs (34), 11/16 inches (17.45 mm);
 - d. Shuttle spring (4E), 1 5/16 inches (33.5 mm).
- 5.5 Roll springs over a flat surface to check for wobble.
- 5.6 Check tube assembly (48) for kinks, breaks or defective tube flares.

- 5.7 Check outside diameter (OD) of fluid piston (16 or 27) and the inside diameter (ID) of the fluid body (21) to determine wear clearance between the two parts. See Table 5-1. Remember that the operating efficiency of the pump depends on maintaining the close tolerance dimension between the piston and the body. **Note:** When checking the ID of the fluid body and the OD of the piston, check at several points around and up and down the bore of the body and the circumference of the piston.

PUMP RATIO AND DASH NO.	ALLOWABLE MAX. CLEARANCE	
	INCH	MM
10:1 - 10	0.010	0.254
20:1 -20	0.008	0.203
30:1 -30	0.007	0.178
35:1 -35	0.005	0.127
60:1 -60	0.005	0.127
100:1 -100	0.004	0.102
101:1 -100	0.004	0.102
125:1 -125	0.004	0.102
150:1 -150	0.003	0.076
200:1 -200	0.002	0.051
300:1 -300	0.001	0.025

Table 5-1 In-service wear limits, fluid piston to fluid body.

- 5.8 Check for smooth movement of shuttle assembly within air valve body. Check contacting surfaces of shuttle and bore of body for dirt, scratches or galling. Check rings (4C) on shuttle for wear, particularly at the tips. Check o-rings (4B) under seal rings for general condition and inspect detent pins (9) for worn condition.
- 5.9 Inspect inlet and outlet check valve seating surfaces in the fluid body (21) for nicks, burrs or excessive wear. Inspect valve bodies, poppets, springs and seats for nicks, burrs, excessive wear or rust.

6.0 REPAIR AND REPLACEMENT

- 6.1 Polish metal parts to remove minute imperfections, minor scratches or scoring. Use wet-or-dry paper grit #600.
- 6.2 Check fluid piston (16 or 27) and fluid body (21). If there is any evidence of galling, replace both piston and body. Carefully polish piston to remove

minor scratches or nicks. Use grit #600. Polish fluid body bore with hone to remove minor imperfections. Use a very fine polishing stone. Recheck for wear clearances as described in paragraph 5.7 and Table 5-1. If imperfections cannot be easily removed, replace piston and body as a matched set. **Note:** The replacement piston-body set also includes the lower housing and gasket.

- 6.3 Check air valve and upper housing assembly. Polish out minor imperfections as described in paragraph 6.2. Keep polishing and honing to an absolute minimum to prevent an increase in wear clearance and resulting loss of air. If imperfections cannot be easily removed, replace the entire air valve and upper housing assembly.
- 6.4 Clean all repaired parts in solvent as described in paragraph 5.1.
- 6.5 Replace all metal parts that fail to pass inspection or are damaged or worn beyond simple repair.
- 6.6 Replace all o-rings, packing retainers, gaskets, springs and detent pins at each pump overhaul. Overhaul kits from Sprague Products conveniently contain all necessary parts to properly overhaul or service the pump. See Table 6-1.

PUMP MODEL NO.	REFERENCE NO.	OVERHAUL KIT
S-216-J-10	79293-11	90680-11
S-216-J-20	77894-11	90680-21
S-216-J-30	77894-21	90680-31
S-216-J-35	77895-81	90680-41
S-216-J-60	77895-11	90680-51
S-216-J-100	77895-21	90680-61
S-216-J-125N	77895-61	90680-01
S-216-J-125	77895-61001	90680-01001
S-216-J-150	77895-31001	90680-71001
S-216-J-200	77895-41001	90680-81
S-216-J-300	77895-51001	90680-91

Table 6-1 Overhaul Kits.

These listed kits contain nitrile seals. Kits can also be ordered with neoprene, viton, and EPR seal material.

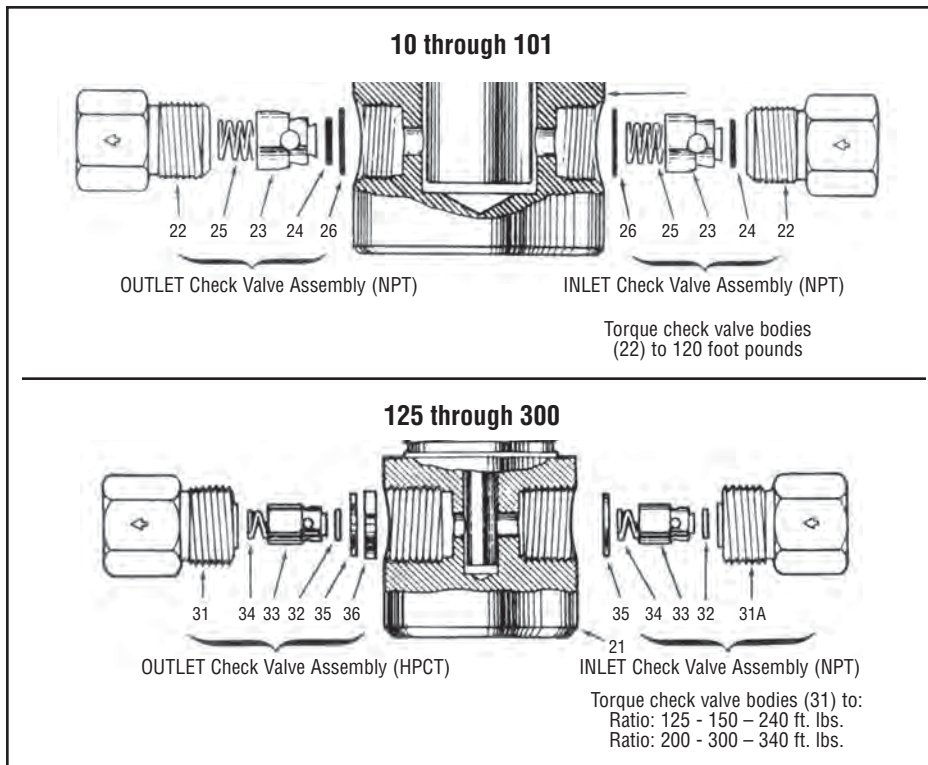

Figure 7-2 Inlet and outlet check valves, sequence of assembly.

7.2 Reassemble and install inlet and outlet check valves into fluid body (21). See Figure 7-1. Note order of assembly and position of poppets (23 and 33) by referring to Figure 7-2. Note torque instructions in illustrations. DO NOT over-torque valve bodies (22 or 31) and be careful to avoid crossing threads when installing check valve bodies. On completion, remove from vise.

7.3 Position fluid piston (16 or 21) in vise. Use aluminum plates in vise jaws. Screw air piston (14) fully onto

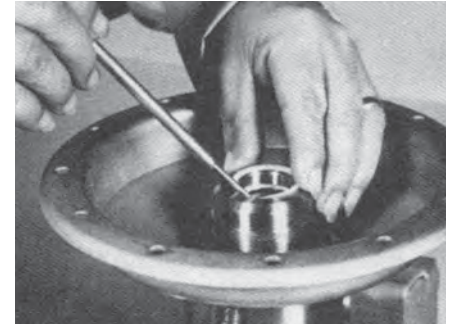

Figure 7-5 Installing seals in fluid body.

fluid piston. Screw nut (38) firmly with 3/4" wrench onto the threaded end of the fluid piston. Install o-ring (15) into groove in air piston (14).

7.4 Screw shifting nut (40) all the way up the long length (one-inch) of threads on the connecting rod (37) with beveled end of nut toward center of rod.

7.5 Insert lockwasher (39) under shifting nut (40) and hold washer next to under side of shifting nut (40). See Figure 7-3. Screw connecting rod (37) end into the threaded end of the fluid piston (16 or 27) until the rod bottoms solidly. Torque shifting nut (40) tightly against plain nut (38) to secure connecting rod. See Figure 7-4.

7.6 Place fluid body (21) and lower housing assembly (19) in vise.

7.7 Install new seals in sealing groove in the bore of the fluid body (21), (see Figure 7-5) in the following sequence relative to pump ratio:

a. 10:1, 20:1 and 30:1 pumps: packing retainer (18)- bottom, o-ring (17)-middle, and packing retainer (18)-top;

b. 35:1 thru 300:1 pumps: back-up ring (18A) on top, o-ring (17) in middle, and packing retainer (18) on bottom of sealing groove. For o-ring replacement of JB models, see page 15.

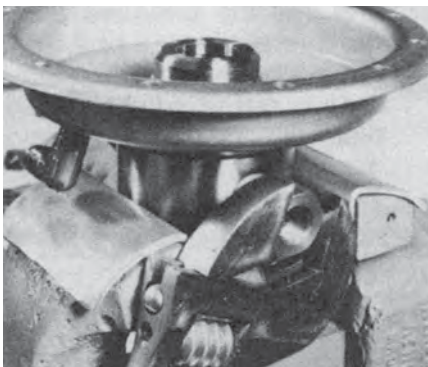

Figure 7-1 Installing check valves.

7.0 REASSEMBLY

Before reassembling pump, wash metallic parts thoroughly in solvent and dry. Lubricate o-rings and threads with Vaseline or hydraulic oil.

7.1 Position fluid body (21) and lower housing (19) in vise. **Note:** Insert soft aluminum plates in vise jaws to cushion grip against fluid body. Refer to paragraph 4-2.



Figure 7-3 Connecting rod with lock washer and shifting nut, ready to be screwed into fluid piston.

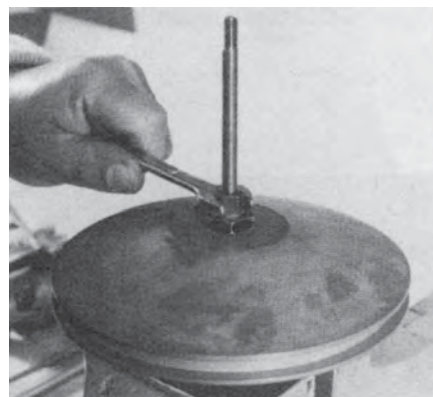

Figure 7-4 Tightening shifting nut to secure connecting rod into fluid piston.

- 7.8 Carefully insert assembled fluid piston (16 or 27) and air piston (14) assembly into bore of fluid body to avoid scratching surfaces. See Figure 7-6. **Note:** Before assembly, lubricate bore and seals of fluid body and fluid piston.
- 7.9 Press down and rotate piston (14) until it bottoms on the top side of the fluid body (21).
- 7.10 Lubricate inside wall of cylinder (13) and o-ring (15) in groove of air piston with Vaseline. Press cylinder into position between air piston and lower housing (19). Position second o-ring (15) around outside of cylinder and in contact with flange of lower housing. See Figure 7-7.
- 7.11 Place stop sleeve over connecting rod and screw nut (44) onto the first several threads of the connecting rod.
- 7.12 Gripping connecting rod (37) and the underside of nut (44), pull rod upward so that the air piston (14) and fluid piston (16 or 27) are in the up position. Remove nut (44) from rod.
- 7.13 Reassemble shuttle assembly and install with "Top" up into air valve

in clockwise opposite positions: 12, 6, 3, 9, etc. Uneven tightening will cause binding between cylinder (13) and air piston (14). **Note:** Connecting rod should be centered in the air valve shuttle assembly center hole if bolts are tightened evenly.

- 7.16 Install the four sets of detent pins (9), springs (8), o-ring packings (7) and bolts (6) into the four threaded ports in valve body (5). Detent pins should engage in lower groove of the shuttle (4A).
- 7.17 Apply air pressure to elbow fitting (47) in the lower housings to move the piston to the up position. See Figure 7-11.

- 7.18 Install self-locking nut (44) on upper threaded end of connecting rod (37). See Figure 7-12. Referring to Figure 7-13 and paragraph 7.5, if no lower threads of connecting rod show above shifting nut (40), then install self-locking nut (44) with at least one upper thread of connecting rod exposed beyond the self-locking nut. Correspondingly, if one or two lower threads of connecting rod are exposed beyond the shifting nut, then install self-locking nut with a like number of connecting rod upper threads exposed beyond the lock nut.

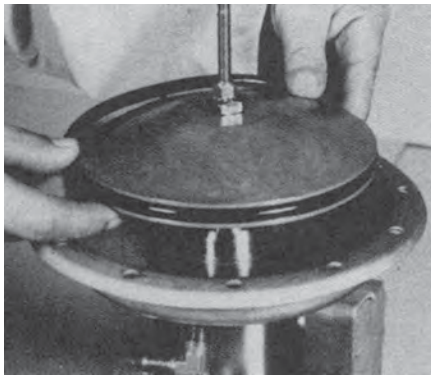

Figure 7-6 Inserting air piston and fluid piston assembly into fluid body.



Figure 7-7 Pressing cylinder into lower housing.

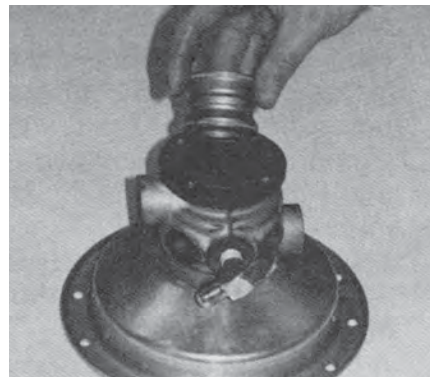

Figure 7-8 Inserting J type shuttle assembly into air valve body.

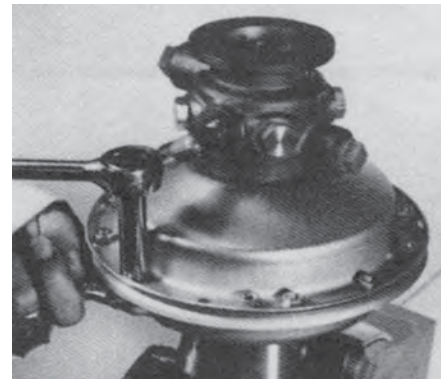

Figure 7-10 Bolting upper and lower housings together.

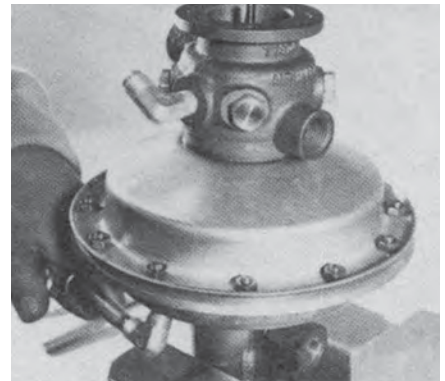

Figure 7-11 Using air pressure to raise shuttle assembly.

and upper body assembly. See Figure 7-8. Press shuttle down evenly and slowly. Move shuttle up and down several times to assure smooth movement.

- 7.14 Install air valve and upper housing assembly onto fluid body and lower housing assembly. Be sure the two elbow fittings for the tube assembly (48) are aligned with each other for later assembly. See Figure 7-9.
- 7.15 Install and loosely tighten the cap screws (45) and nuts (46) around the housing flanges. Tighten evenly

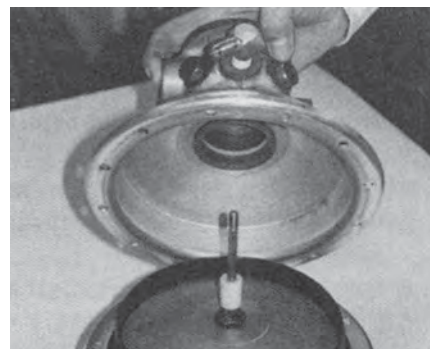

Figure 7-9 Air valve and upper housing assembly ready for attachment to lower housing assembly.

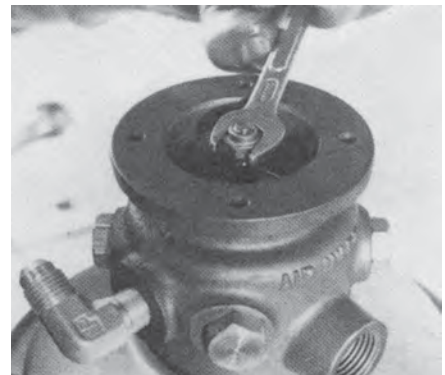

Figure 7-12 Installing self-locking nut on connecting rod.

- 7.19 Check for smooth movement up and down of shuttle. Using shop air (approx. 10 psi), inject air to elbow in lower housing (19) to raise shuttle to up position. Manually push down on the shuttle. Repeat this up and down movement several times to determine smoothness of movement. Movement should be smooth; if not, air piston (14) is binding against cylinder wall (13). Binding is caused by uneven tightening of the 12 screws (45) and nuts (46) at the housing flange. Retighten screws evenly per paragraph 7.15.
- 7.20 With pump movement assured, install new o-ring (2), cover (1) and four screws (3) to close the air valve portion of the pump.
- 7.21 Reinstall tube assembly (48) to the elbows in the upper and lower housings.
- 7.22 For final check of movement, inject air pressure to air inlet port. Movement of assembled shuttle, air piston and fluid piston should be smooth and regular.

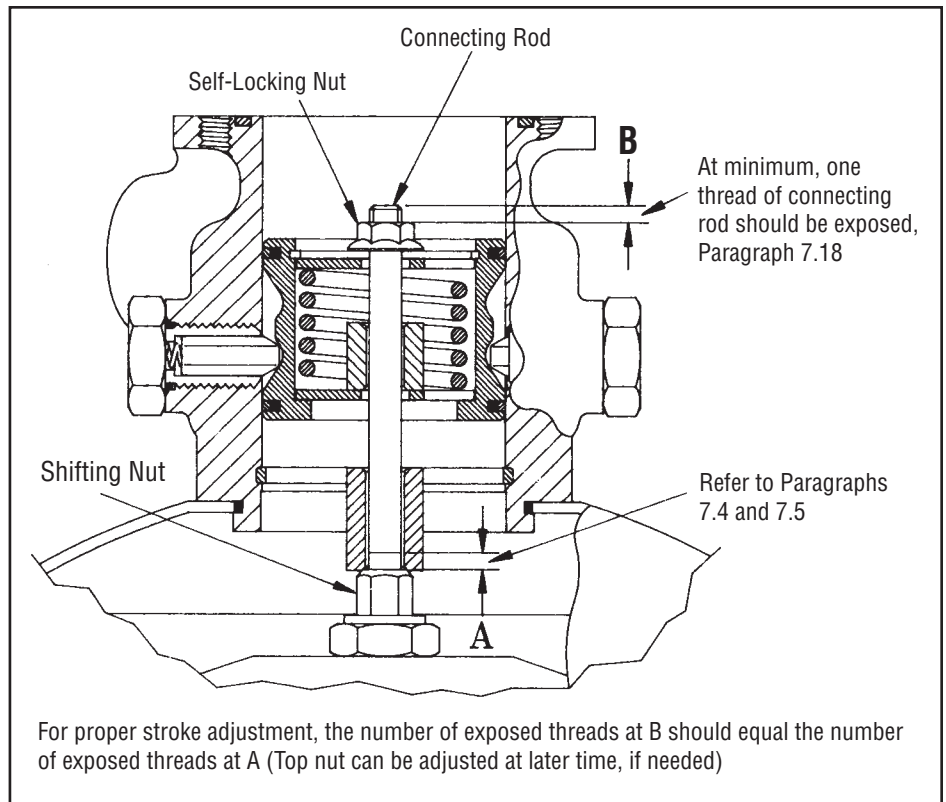

Figure 7-13 J air valve stroke adjustment.

8.0 TEST

- 8.1 Install pump into a typical circuit. See Figure 1-2. Operate pump in accordance with Section 2.0, Operation.
- 8.2 Conduct tests operating pump at different driving air pressures. Close fluid shut-off valve in pump discharge line to permit pump to build up its maximum pressure output. At this point the pump will slow to a stop, indicating a pressure balance has been reached between fluid pressure and driving air pressure. The pump will automatically restart when pressure imbalance occurs.
- 8.3 Compute ratio of fluid maximum output pressure to driving air input pressure. Compare pump dash number to pump's rated fluid output pressure. Refer to Table 8-1.

PUMP MODEL DASH NO.	INPUT OPERATING AIR PRESSURE		OUTPUT FLUID PRESSURE	
	PSI	BAR	PSI	BAR
-10	40	2.72	410	28
	100	6.80	1,025	71
-20	40	2.72	760	52
	100	6.80	1,910	132
-30	40	2.72	1,280	88
	100	6.80	3,200	221
-35	40	2.72	1,895	131
	100	6.80	4,760	328
-60	40	2.72	2,545	176
	100	6.80	6,330	437
-100	40	2.72	3,665	253
	100	6.80	9,100	628
-101	40	2.72	4,000	276
	100	6.80	10,000	689
-125	40	2.72	5,000	345
	100 (HPCT)	6.80	12,500	862
-150	40	2.72	6,530	450
	100	6.80	16,200	1,117
-200	40	2.72	10,160	701
	100	6.80	24,900	1,717
-300	40	2.72	14,650	1010
	100	6.80	36,500	2,517

Table 8-1 Rated air input pressures to fluid output pressures.

9.0 IPB AND SUPPLIMENTAL DATA

Illustrated Parts Breakdown (IPB) enclosed to provide additional data on the S-216-J-() basic pump. Other pump data may be included as required.

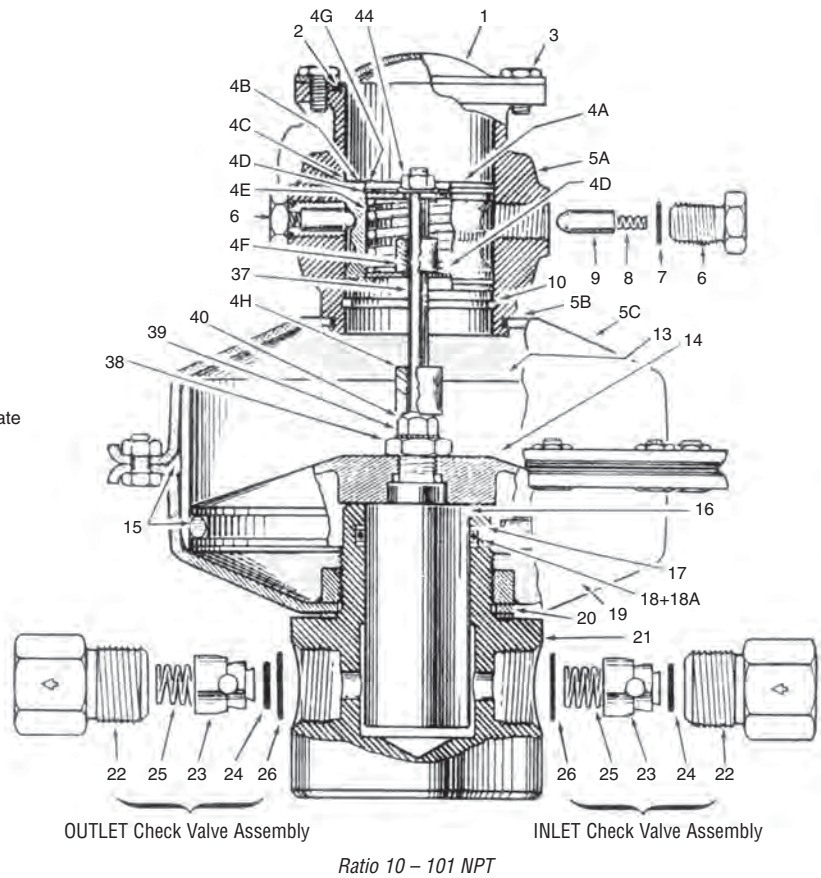
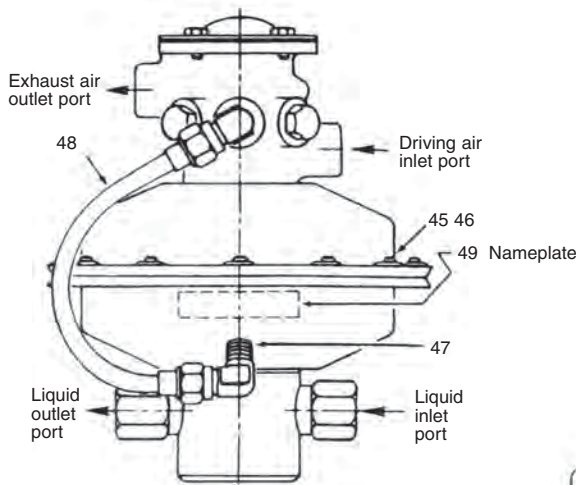

OVERHAUL KIT

The Overhaul Kit contains replacement parts including Inlet and Outlet Check Valve O-rings and Springs; Detent Springs, Pins and O-rings; Shuttle Valve Rings and O-rings as well as other O-rings, Retainers, and Connecting Self-Locking Nut and Washer.

The kits listed below apply only to standard pumps with elastomeric type seals. Standard kit seals are nitrile. Optional kits with neoprene, Viton® and EPR seals are available. In the kit numbers listed below, the two digits after the dash indicate the choice of optional seal materials. The first of those digits indicates the pump ratio while the second indicates the seal materials.

- 00000-X X = pump ratio
- 00000-X1 1 = nitrile seals
- 00000-X3 3 = Viton® seals
- 00000-X4 4 = EPR seals

Ordering Example: An Overhaul Kit with neoprene seals is needed for an S-216-J-30. The standard kit is 90680-31 with the 3 indicating a 30 ratio pump and the 1 indicating nitrile seals. Change the last digit from 1 to 2 to indicate neoprene seals. The new number for the Overhaul Kit is 90680-32.

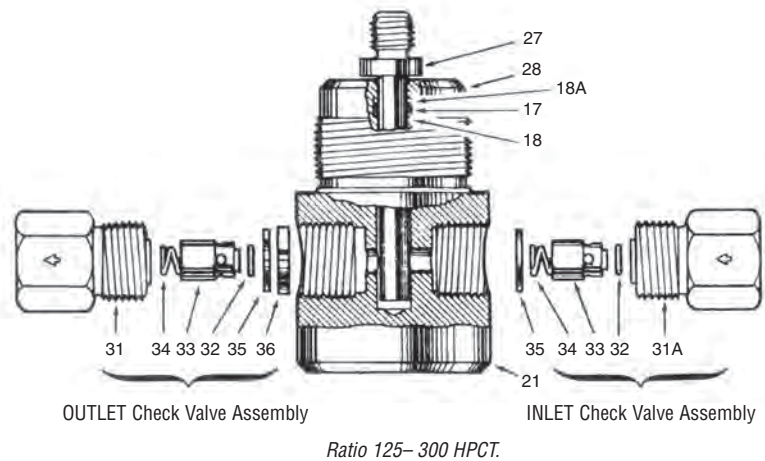

Pump Model Number	Reference Number	Overhaul Kit Number
S-216-JB-35	94186-035-01	94186-035-01-K
S-216-JB-60	94186-060-01	94186-060-01-K
S-216-JB-100	94186-100-01	94186-100-01-K
S-216-JB-101 (NPT)	94186-101-01	94186-101-01-K
S-216-JB-125 (HPCT)	94186-125-11	94186-125-11-K
S-216-JB-150	94186-150-11	94186-150-11-K
S-216-JB-200	94186-200-10	94186-200-11-K
S-216-JB-300	94186-300-11	94186-300-11-K

Pump Model Number	Reference Number	Overhaul Kit Number
S-216-J-10	79293-11	90680-11
S-216-J-20	77894-11	90680-21
S-216-J-30	77894-21	90680-31
S-216-J-35	77895-81	90680-41
S-216-J-60	77895-11	90680-51
S-216-J-100	77895-21	90680-61
S-216-J-125 (NPT)	77895-61	90680-01
S-216-J-125 (HPCT)	77895-61001	90680-01001
S-216-J-150	77895-31001	90680-71001
S-216-J-200	77895-41001	90680-81
S-216-J-300	77895-51001	90680-91

Viton is a registered trademark of DuPont Dow Elastomers.

Item No	Model Number	Part Name	Pump Ratio Dash Number															
			-10	-20	-30	-35	-60	-100	-125 NPT	-125 HPCT	-150	-200	-300					
	S-216-J-10	Pump Assy., 10:1 Ratio (79293-11)	•															
	S-216-J-20	Pump Assy., 20:1 Ratio (77894-11)		•														
	S-216-J-30	Pump Assy., 30:1 Ratio (77894-21)			•													
	S-216-J-35	Pump Assy., 35:1 Ratio (77895-81)				•												
	S-216-J-60	Pump Assy., 60:1 Ratio (77895-11)					•											
	S-216-J-100	Pump Assy., 100:1 Ratio (77895-21)						•										
	S-216-J-125N	Pump Assy., 125:1 Ratio (77895-61) NPT							•									
	S-216-J-125	Pump Assy., 125:1 Ratio (77895-61001)								•								
	S-216-J-150	Pump Assy., 150:1 Ratio (77895-31001)									•							
	S-216-J-200	Pump Assy., 200:1 Ratio (77895-41001)										•						
	S-216-J-300	Pump Assy., 300:1 Ratio (77895-51001)											•					
	Part No.																	
1	S-216-17-1	Cover air valve	1	1	1	1	1	1	1	1	1	1	1	1	1	1	1	1
2	91417-138	O-ring	1	1	1	1	1	1	1	1	1	1	1	1	1	1	1	1
3	MS90725-3	Screw cap, 1/4-20 X 1/2 long	4	4	4	4	4	4	4	4	4	4	4	4	4	4	4	4
4	90535-1	Air valve and housing assembly	1	1	1	1	1	1	1	1	1	1	1	1	1	1	1	1
—	90654-1	Shuttle Assembly	1	1	1	1	1	1	1	1	1	1	1	1	1	1	1	1
4A	90522	Shuttle	1	1	1	1	1	1	1	1	1	1	1	1	1	1	1	1
4B	91417-029	O-ring	2	2	2	2	2	2	2	2	2	2	2	2	2	2	2	2
4C	90524	Ring	2	2	2	2	2	2	2	2	2	2	2	2	2	2	2	2
4D	92247	Flange	2	2	2	2	2	2	2	2	2	2	2	2	2	2	2	2
4E	90600	Spring	1	1	1	1	1	1	1	1	1	1	1	1	1	1	1	1
4F	92249	Guide sleeve	1	1	1	1	1	1	1	1	1	1	1	1	1	1	1	1
4G	90685	Snap ring	1	1	1	1	1	1	1	1	1	1	1	1	1	1	1	1
4H	92248	Stop sleeve	1	1	1	1	1	1	1	1	1	1	1	1	1	1	1	1
—	90651-1	Body and housing assembly	1	1	1	1	1	1	1	1	1	1	1	1	1	1	1	1
6	78238	Detent bolt	4	4	4	4	4	4	4	4	4	4	4	4	4	4	4	4
7	79552-5	Detent O-ring	4	4	4	4	4	4	4	4	4	4	4	4	4	4	4	4
8	S-216-24	Detent spring	4	4	4	4	4	4	4	4	4	4	4	4	4	4	4	4
9	82871	Detent pin	4	4	4	4	4	4	4	4	4	4	4	4	4	4	4	4
10	S-216-56	Stop	1	1	1	1	1	1	1	1	1	1	1	1	1	1	1	1
13	S-216-13	Cylinder	1	1	1	1	1	1	1	1	1	1	1	1	1	1	1	1
14	S-216-4	Air piston	1	1	1	1	1	1	1	1	1	1	1	1	1	1	1	1
15	79550-60	O-ring	2	2	2	2	2	2	2	2	2	2	2	2	2	2	2	2
16	S-216-61-10SS	Liquid piston	1															
17	94204-225	Seal, nitrile	1															
18	MS28783-3	Packing retainer, Teflon®	2															
—	89801-10	Body and housing assembly	1															
16	S-216-10-20	Liquid piston		1														
17	79550-25-1*	O-ring, nitrile		1														
18	MS28782-25	Packing retainer, Teflon		2														
—	89801-20	Body and housing assembly		1														
16	S-216-10-30	Liquid piston			1													
17	79550-20-1*	O-ring, nitrile			1													
18	MS28782-20	Packing retainer, Teflon			2													
—	89801-30	Body and housing assembly			1													

*Seal Materials: Neoprene, Viton and EPR.

Teflon is a registered trademark of the DuPont Company.

Item No	Model Number	Part Name	Pump Ratio Dash Number											
			-10	-20	-30	-35	-60	-100	NPT -125	HPCT -125	-150	-200	-300	
16	S-216-10-35	Liquid piston				1								
17	79550-17-1*	O-ring, nitrile				1								
18	MS28782-17	Packing retainer, Teflon				1								
18A	90098-35	Back-up ring				1								
—	89801-35	Body and housing assembly				1								
—	89803-60-1	Piston, body and housing assembly					1							
19	89793	Lower housing					1							
20	S-216-20	Gasket					1							
—	77890-11	Piston and body assembly					1							
16	S-216-10-60	Liquid piston					1							
21	77888-1	Liquid body					1							
17	79550-14-1*	O-ring, nitrile					1							
18	MS28782-14	Packing retainer, Teflon					1							
18A	90098-60	Back-up ring					1							
—	89803-100-1	Piston, body and housing assembly						1						
19	89793	Lower housing						1						
20	S-216-20	Gasket						1						
—	77890-21	Piston and body assembly						1						
16	S-216-11-100	Liquid piston						1						
21	77888-2	Liquid body						1						
17	79550-12-1*	O-ring, nitrile						1						
18	MS28782-12	Packing retainer, Teflon						1						
18A	90098-100	Back-up ring						1						
—	89803-125N-1	Piston, body and housing assembly							1					
—	89803-125-1	Piston, body and housing assembly								1				
19	89793	Lower housing							1	1				
20	S-216-20	Gasket)							1	1				
—	77890-71	Piston and body assembly							1	1				
16	77890-61	Piston and body assembly									1			
27	S-216-11-125	Liquid piston							1	1				
21	77888-5	Liquid Body							1					
21	77889-2	Liquid body									1			
17	79550-11-1*	O-ring, nitrile							1	1				
18/18A	90098-125	Back-up ring							2	2				
—	89803-150-1	Piston, body and housing assembly										1		
19	89793	Lower housing										1		
20	S-216-20	Gasket										1		
—	77890-31	Piston and body assembly										1		
16	S-216-11-150	Liquid piston										1		
21	77889-3	Liquid body										1		
17	79550-10-1*	O-ring, nitrile										1		
18/18A	90098-150	Back-up ring										2		
—	89803-200-1	Piston, body and housing assembly											1	
19	89793	Lower housing											1	
20	S-216-20	Gasket											1	
—	77890-41	Piston and body assembly											1	
27	S-216-11-200	Liquid piston											1	
28	77889	Liquid body											1	
17	79550-8-1*	O-ring, nitrile											1	
18	MS28782-8	Packing retainer, Teflon											1	
18A	90098-200	Back-up											1	
—	89803-300-1	Piston, body and housing assembly												1
19	89793	Lower housing												1
20	S-216-20	Gasket												1
—	77890-51	Piston and body assembly												1
27	S-216-11-300	Liquid piston												1
28	77889-1	Liquid body												1
17	91417-011-1*	O-ring, nitrile												1
18	MS28782-6	Packing retainer, Teflon												1
18A	90098-300	Back-up ring												1

*Seal Materials: Neoprene, Viton and EPR.

Item No	Model Number	Part Name	Pump Ratio Dash Number											
			-10	-20	-30	-35	-60	-100	NPT -125	HPCT -125	-150	-200	-300	
—	82650-21	Valve Assy., outlet (3/8NPT thread)	1	1	1	1	1	1	1	1				
22	88906	Check valve body	1	1	1	1	1	1	1					
—	79420-3	Poppet assembly	1	1	1	1	1	1	1					
23	79420-1	Poppet	1	1	1	1	1	1	1					
24	79550-8-1	Packing O-ring, nitrile	1	1	1	1	1	1	1					
25	S-216-23	Spring	1	1	1	1	1	1	1					
26	91417-019-1	O-ring, nitrile	1	1	1	1	1	1	1					
—	82651-21	Valve Assy., inlet (3/8 NPT thread)	1	1	1	1	1	1	1					
22	88906	Check valve body	1	1	1	1	1	1	1					
—	79420-3	Poppet assembly	1	1	1	1	1	1	1					
23	79420-1	Poppet	1	1	1	1	1	1	1					
24	79550-8-1	Packing O-ring, nitrile	1	1	1	1	1	1	1					
25	S-216-23	Spring	1	1	1	1	1	1	1					
26	91417-019-1	O-ring, nitrile	1	1	1	1	1	1	1					
—	82648-11	Valve Assy., outlet (1/4 HPCT thread)								1	1	1	1	
31	89298-1	Outlet Check valve body								1	1	1	1	
32	79550-5-1	Packing O-ring, nitrile								1	1	1	1	
33	89297	Poppet								1	1	1	1	
34	S-216-63	Spring								1	1	1	1	
35	S-216-28-8	Outlet check valve gasket								1	1	1	1	
36	S-216-27-4	Outlet check valve seat only								1	1	1	1	
—	82649-11	Valve Assy., inlet (1/4 NPT thread)								1	1	1	1	
31A	89298	Inlet Check valve body								1	1	1	1	
32	79550-5-1	Packing O-ring, nitrile								1	1	1	1	
33	89297	Poppet								1	1	1	1	
34	S-216-63	Spring								1	1	1	1	
35	S-216-28-10	Inlet Check valve gasket								1	1	1	1	
37	90523	Connecting rod	1	1	1	1	1	1	1	1	1	1	1	1
38	93776-1	Plain nut, 1/2-20	1	1	1	1	1	1	1	1	1	1	1	1
39	MS35335-33	Washer/Lock, external tooth, 1/4	1	1	1	1	1	1	1	1	1	1	1	1
40	78259	Shifting nut	1	1	1	1	1	1	1	1	1	1	1	1
44	90686	Self-locking nut, 1/4-28	1	1	1	1	1	1	1	1	1	1	1	1
45	MS90725-3	Screw cap, 1/4-20 X 1/2 long	16	16	16	16	16	16	16	16	16	16	16	16
46	MS51967-2	Plain nut, 1/4-20	12	12	12	12	12	12	12	12	12	12	12	12
47	93594	Elbow, 90°	2	2	2	2	2	2	2	2	2	2	2	2
48	88501	Tube assembly	1	1	1	1	1	1	1	1	1	1	1	1
49	80063-2	Nameplate	1	1	1	1	1	1	1	1	1	1	1	1

S216-JB ASSEMBLY

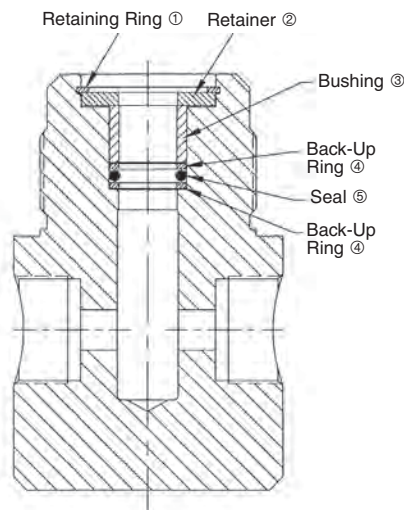

Model	Body & Housing Assembly	① Retaining Ring	② Retainer	③ Bushing	④ Back-Up Ring 2(Req'd)	⑤ Seal
S-216-JB-035	94192-035	94193-125	94158-035	94157-035	90098-35	94172-212
S-216-JB-060	94192-060	94193-125	94158-060	94157-060	90098-60	94172-116
S-216-JB-100	94192-100	94193-125	94158-100	94157-100	90098-100	94172-114
S-216-JB-101	94192-101	94193-125	94158-100	94157-101	90098-101	94172-114
S-216-JB-125	94195-125	94193-125	94158-125	94157-125	90098-125	94172-113
S-216-JB-150	94195-150	94193-125	94158-150	94157-150	90098-150	94172-112
S-216-JB-200	94195-200	94193-125	94158-200	94157-200	90098-200	94172-110
S-216-JB-300	94195-300	94193-125	94158-300	94157-300	90098-300	94172-011

Disassembly: 1. Remove retaining ring
2. Lift out retainer, bushing and seals

Assembly is reverse of disassembly



High Pressure Equipment
Sprague® Products

2955 W. 17th Street • Erie, Pennsylvania 16505 U.S.A.
Phone: (814) 838-2028 • 1-800-289-7447
Fax: (814) 838-6075 • E-Mail: sales@highpressure.com
www.HighPressure.com

© 2017 High Pressure Equipment Company
Printed in U.S.A.