

SUPERCHARGE SHOP AIR OR BOTTLED GAS WITH SPRAGUE PRODUCTS GAS BOOSTER

Sprague Products pneumatic boosters offer a cost effective way to compress shop air or bottled gas to meet various requirements for higher pressure, lower volume air or gas.

Industrial applications include charging accumulators, inflating high pressure tires or charging shock struts from lower pressure supply sources, the transferring of gas from a supply cylinder to another container or the actuating of air chucks in machine tools. Where production machinery or test set-ups require higher air pressures than normally provided by the shop air system, Sprague Products boosters can provide the extra muscle needed to operate the equipment.

The Sprague Products booster can be installed as a component or can be supplied as a complete, ready-to-use power package. Use of the Sprague Products booster power unit eliminates the need to develop the basic power supply circuit, the time to select and buy the needed accessories, and the time required to test and troubleshoot the circuit.

Because of their compact size and low cost, Sprague Products boosters can be combined in high-low combinations to meet higher flow and pressure requirements.

Being air driven and having no electrical connections, Sprague Products pneumatic boosters are non-sparking. These boosters can be used safely in the presence of flammable or explosive liquids or vapors.

Sprague Products boosters and other Sprague Products pneumatic products are designed to a 4 to 1 minimum safety factor.

A variety of Sprague Products boosters have been developed to convert precharge low gas pressures to higher gas pressures.

HOW THE SPRAGUE PRODUCTS BOOSTERS WORK

The Sprague Products gas booster is a piston-type, air-operated booster. It uses a mechanically operated, snap-action air selector valve to cycle the booster.

The Sprague Products boosters, like Sprague Product air driven hydraulic pumps, employ the piston differential areas principle—a large area air piston, driven at low air pressure to drive a small area compression piston which converts input gas to higher pressure, lower volume output gas.

The booster gas output or discharge pressure developed by the compression piston is determined by the ratio between the area of the air piston, the operating air pressure and the available precharge pressure. The function of the precharge pressure to the booster is to charge the high pressure cylinder inside the booster with gas, reducing the time required to reach higher pressures, and the time to return the compression piston and the air piston for the next compression cycle.

The Sprague Products booster works rapidly to reach the required pressure, then stops at a pressure balance. The booster will hold the pressure balance indefinitely with minimal energy consumption, heat build-up or parts movement. When a pressure imbalance occurs, the booster will automatically restart to restore the pressure balance.

By using a pressure regulator on the operating air supply line, the outlet gas pressure can be accurately adjusted to any pressure level between the precharge pressure and the maximum discharge pressure.

With some Sprague Products booster models, the pumping or high pressure section is cooled with exhaust air piped from the air-driving section of the booster. In other boosters, the pumping section employs external fins to dissipate the heat.

Compared to other air-operated gas boosters, the Sprague Products booster does the same job but with fewer moving parts and seals for less maintenance throughout its service life.

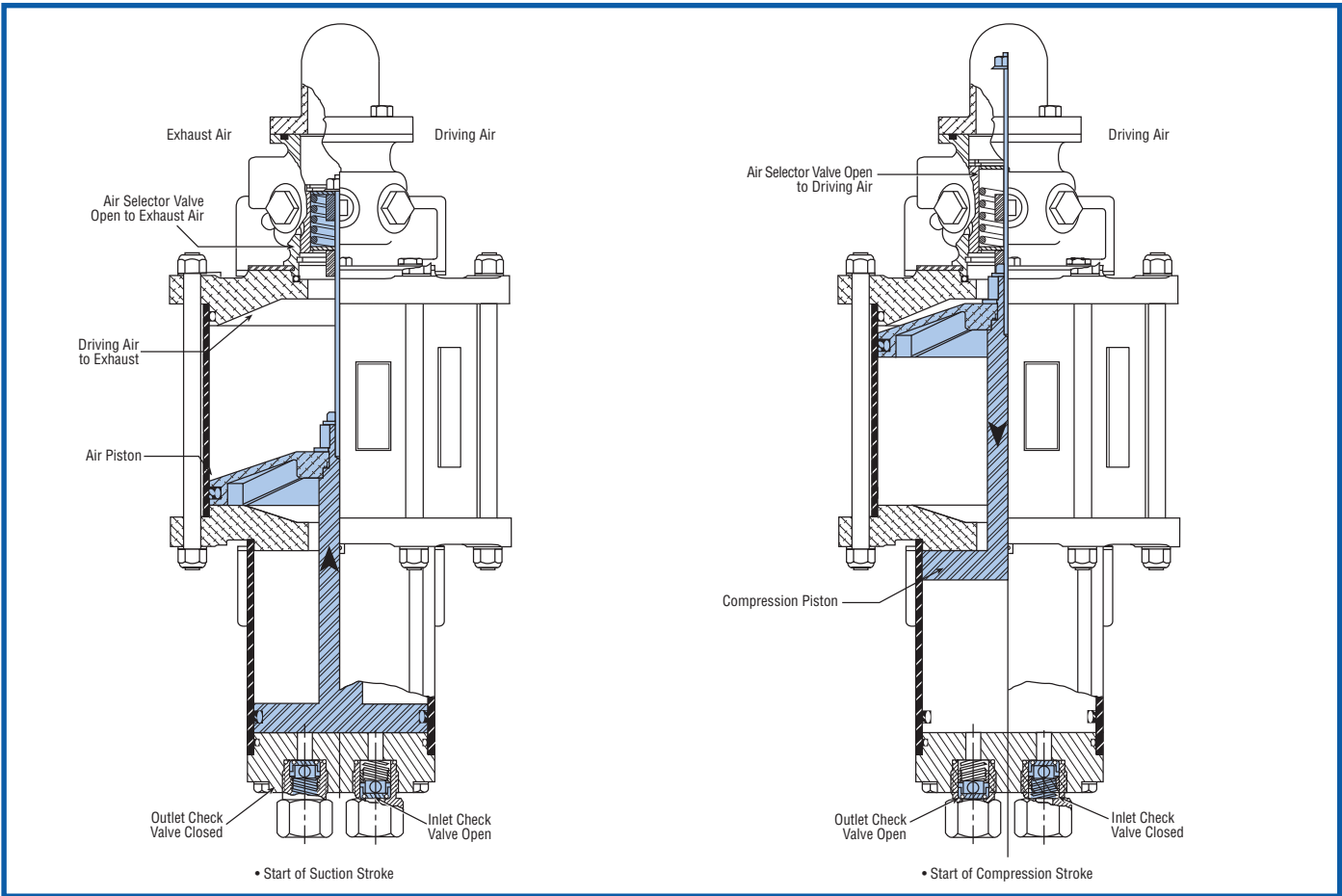

GAS BOOSTER ACCESSORIES

To compress shop air or bottled gas to higher pressures, Sprague Products boosters are combined with accessories to provide complete circuits as shown below.

An air control unit and shut-off valve are installed in the driving air side of booster. Noise is dampened with a muffler. An air filter (10 micron) is recommended in the gas precharge line. On

the gas discharge side, a pressure gauge, shut-off and bleed valves are installed.

For convenience, boosters combined with compatible accessories can be obtained as complete, ready-to-use power units.

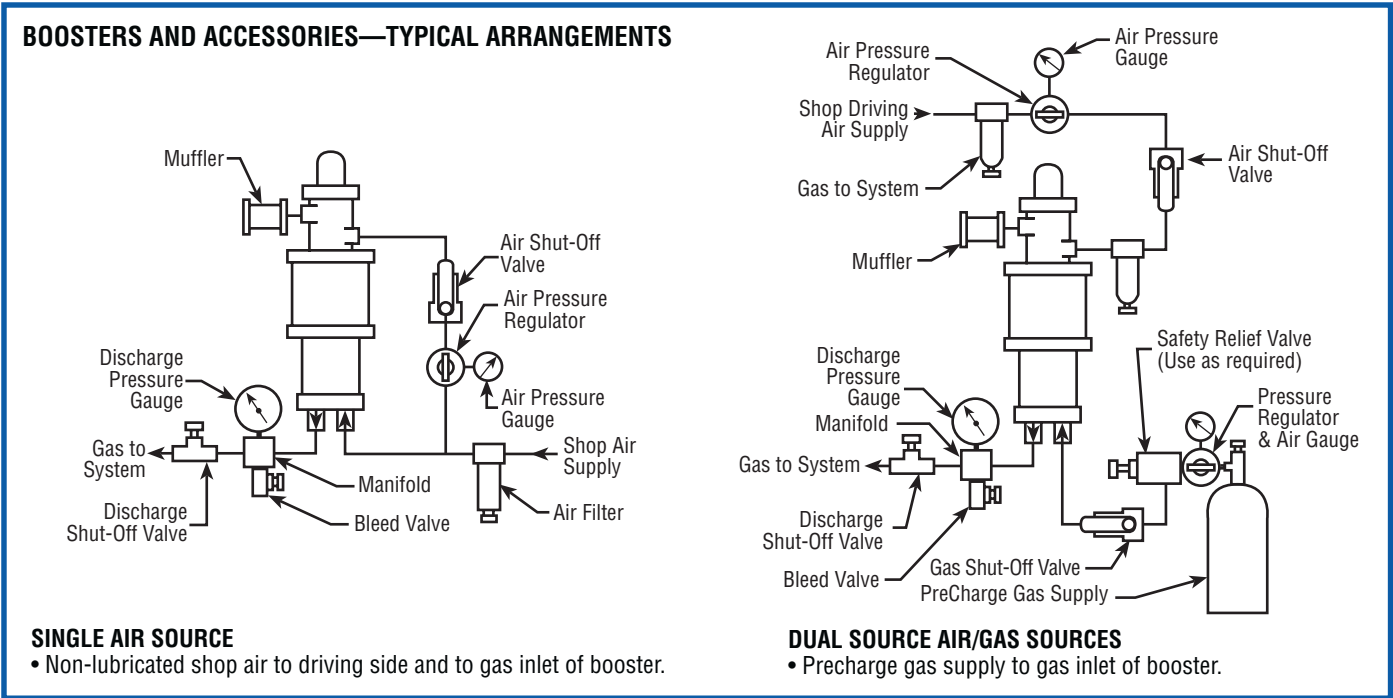

GAS BOOSTER SELECTION

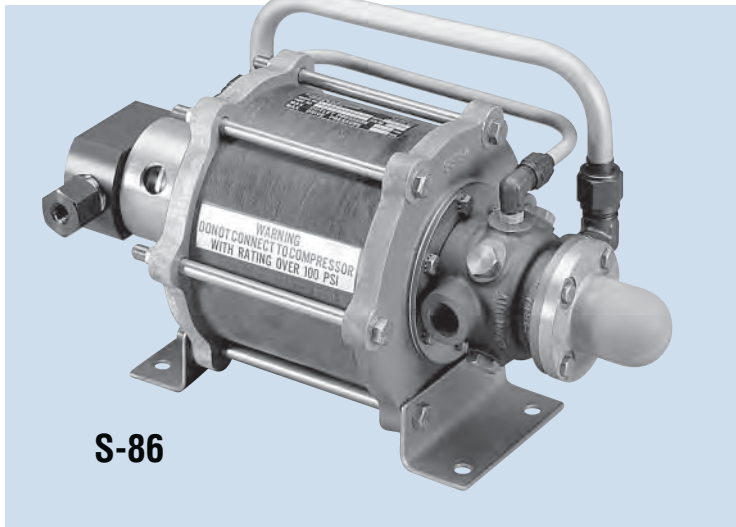

S-86

In general, an air or gas charging application requires a specific volume to be brought to a specific pressure within a given amount of time. The adjacent Tables will assist you in selecting the most efficient ratio Sprague Products booster for your application requirements.

A typical hose pressure testing application:

- a. Hose with one cubic foot volume is to be pressure tested at 500 psig. Pressure level is to be reached in three minutes. Available shop air is 150 psi.
- b. Using Table 1, Low Pressure Gas Boosters Performance, page 22, find the required receiver pressure of 500 psi. Compare the figures found in the 500 psi discharge pressure column to the desired time of three minutes. The column figures nearest to three minutes is 2 minutes, 45 seconds with a discharge rate of 4.4 standard cubic feet per minute. So, the 5:1 ratio booster will do this job more efficiently than a 15:1 ratio booster.
- c. Note that the booster driving air pressure and above calculations are based on 100 psi, so the shop air pressure of 150 psi must be reduced to 100 psi driving air to operate the booster. Shop air of 150 psi should still be supplied to the inlet port of the compressing portion of the booster. The higher the precharge inlet pressure, the faster the discharge outlet pressure will be reached.
- d. For the above hose test, the S-86-JN-5 booster or S-486-JN-5 booster power unit could be used.

| Low Pressure Booster Ratio | Precharge Inlet Air Range-psi | Outlet Air Range-psi |
|----------------------------|-------------------------------|----------------------|
| 2:1 | 25-450 | 50-450* |
| 5:1 | 50-1100 | 125-1100* |
| 15:1 | 100-3100 | 375-3100* |

*Based on 200 psi driving air

| High Pressure Booster Ratio | Precharge Inlet Air Range-psi | Outlet Air Range-psi |
|-----------------------------|-------------------------------|----------------------|
| 30:1 | 200-6000 | 750-6000* |
| 60:1 | 300-6100 | 1500-6100** |
| 100:1 | 500-10300 | 2500-10300** |

*Based on 200 psi driving air.

**Based on 100 psi driving air.

TABLE 1, LOW PRESSURE GAS BOOSTERS PERFORMANCE (approximate performance based on air consumption of 80 SCFM)

| BOOSTER RATIO | INLET PORT PRECHARGE PRESSURE-psi | OUTLET PORT PRESSURE (with 100 psi driving air) | DISCHARGE CAPACITY—Standard Cubic Feet per Minute (SCFM) DISCHARGE PRESSURE—psi | | | | | | | | | | | |
|--|-----------------------------------|---|--|------|------|------|------|------|-------|-------|------|-------|-------|--|
| | | | 125 | 150 | 175 | 200 | 300 | 400 | 500 | 600 | 800 | 1000 | 1500 | |
| 2:1 | 75 | 225 | 15.8 | 14.2 | 12.6 | 11.1 | | | | | | | | |
| | 100 | 225 | | 19.6 | 17.3 | 13.7 | | | | | | | | |
| | 125 | 225 | | 22.5 | 20.6 | 15.0 | | | | | | | | |
| 5:1 | 50 | 550 | | | | 4.1 | 3.6 | 2.7 | 1.6 | | | | | |
| | 100 | 550 | | | | 8.7 | 6.8 | 5.2 | 3.0 | | | | | |
| | 150 | 550 | | | | 13.7 | 11.1 | 8.0 | 4.4 | | | | | |
| 15:1 | 100 | 1550 | | | | | | 2.2 | 1.9 | 1.7 | 1.4 | 1.2 | — | |
| | 200 | 1550 | | | | | | 6.5 | 5.7 | 5.2 | 4.5 | 4.1 | 1.1 | |
| | 300 | 1550 | | | | | | 10.7 | 9.5 | 8.4 | 6.2 | 5.1 | 1.5 | |
| Time required in minutes/seconds to fill a one cubic foot receiver to listed Discharge Pressures RECEIVER PRESSURE—psi (one cubic foot) | | | | | | | | | | | | | | |
| | | | 125 | 150 | 175 | 200 | 300 | 400 | 500 | 600 | 800 | 1000 | 1500 | |
| 2:1 | 75 | 225 | 0-12 | 0-19 | 0-27 | 0-38 | | | | | | | | |
| | 100 | 225 | | 0-8 | 0-14 | 0-25 | | | | | | | | |
| | 125 | 225 | | 0-5 | 0-8 | 0-17 | | | | | | | | |
| 5:1 | 50 | 550 | | | | 2-4 | 2-58 | 5-40 | 9-22 | | | | | |
| | 100 | 550 | | | | 0-42 | 1-40 | 2-50 | 4-50 | | | | | |
| | 150 | 550 | | | | 0-12 | 0-36 | 1-27 | 2-45 | | | | | |
| 15:1 | 100 | 1550 | | | | | | 7-30 | 10-48 | 14-56 | 23-6 | 33-12 | | |
| | 200 | 1550 | | | | | | 1-45 | 2-52 | 4-5 | 6-54 | 9-55 | 20-48 | |
| | 300 | 1550 | | | | | | 0-31 | 1-18 | 2-8 | 4-0 | 6-16 | 14-28 | |

TABLE 2, HIGH PRESSURE GAS BOOSTERS PERFORMANCE (approximate performance based on air consumption of 80 SCFM)

| BOOSTER RATIO | INLET PORT PRECHARGE PRESSURE-psi | OUTLET PORT PRESSURE (with 100 psi driving air) | DISCHARGE CAPACITY—Standard Cubic Inches per Minute (SCIM) DISCHARGE PRESSURE—psi | | | | | | | | | | | |
|--|-----------------------------------|---|--|------|------|------|------|------|------|-------|------|------|------|--------|
| | | | 1000 | 2000 | 2500 | 2750 | 3000 | 4000 | 5000 | 6000 | 7000 | 8000 | 9000 | 10,000 |
| 30:1 | Min. 200* | 3000 | 2800 | 2000 | 1400 | 950 | | | | | | | | |
| | 300 | 3000 | 5200 | 4200 | 3200 | 2100 | | | | | | | | |
| | 500 | 3000 | 12500 | 9500 | 7000 | 3800 | | | | | | | | |
| 60:1 | Min. 300* | 6100 | 3800 | 3200 | 3100 | 3050 | 3000 | 3000 | 2900 | 2000 | | | | |
| | 500 | 6100 | 6600 | 6000 | 5900 | 5850 | 5800 | 5750 | 5700 | 4500 | | | | |
| 100:1 | Min. 800* | 10,300 | | | | | 5074 | 5000 | 4800 | 4700 | 4500 | 4250 | 3800 | 3000 |
| | 1000 | 10,300 | | | | | 7000 | 6700 | 6600 | 6400 | 6100 | 5600 | 5000 | 3500 |
| Time required in minutes/seconds to fill a 100 cubic inch receiver to listed Discharge Pressures RECEIVER PRESSURE—psi (100 cubic inches) | | | | | | | | | | | | | | |
| | | | 1000 | 2000 | 2500 | 2750 | 3000 | 4000 | 5000 | 6000 | 7000 | 8000 | 9000 | 10,000 |
| 30:1 | Min. 200* | 3000 | 1-15 | 3-52 | 6-35 | 9-50 | | | | | | | | |
| | 300 | 3000 | 0-35 | 1-48 | 2-50 | 4-30 | | | | | | | | |
| | 500 | 3000 | 0-10 | 0-45 | 1-0 | 1-30 | | | | | | | | |
| 60:1 | Min. 300* | 6100 | 0-53 | 2-54 | 3-32 | 4-30 | 5-7 | 7-24 | 9-18 | 12-20 | | | | |
| | 500 | 6100 | 0-40 | 1-30 | 1-50 | 2-15 | 2-38 | 3-25 | 4-25 | 6-40 | | | | |
| 100:1 | Min. 800* | 10,300 | | | | | 2-47 | 4-7 | 5-22 | 6-25 | 7-40 | 8-38 | 9-46 | 11-13 |
| | 1000 | 10,300 | | | | | 1-30 | 2-50 | 3-45 | 4-30 | 5-20 | 6-10 | 7-0 | 8-30 |

*Minimum precharge required for satisfactory operation

GAS BOOSTERS

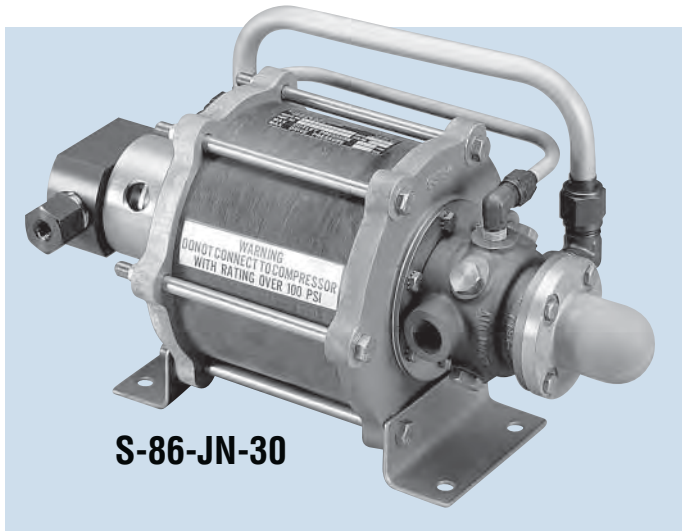

A competitively priced series of versatile gas boosters is offered in six popular design ratios: 2:1, 5:1, 15:1, 30:1, 60:1 and 100:1

These non-contaminating gas boosters are suitable for general use or for use in cleanrooms or laboratories. Since these boosters are provided with self-lubricating dynamic seals, they can be driven with clean dry air.

Being air driven, these boosters are non-sparking and safe for use in hazardous areas.

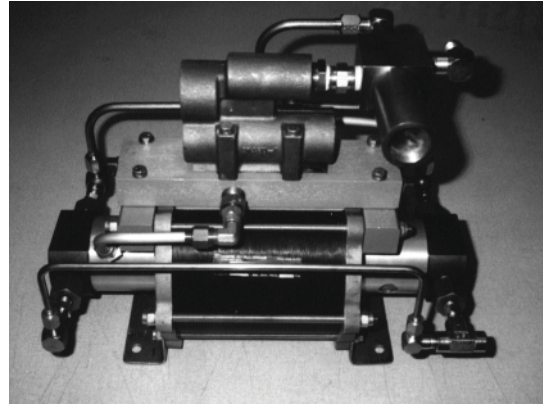

S-86-JN-30/30 (93639-11)
Used on ground support equipment and nitrogen gas charging carts.

TABLE 3, S-86-JN GAS BOOSTER PERFORMANCE AND DATA (NOMINAL)

| Gas Booster or Power Unit | | | Driving Air Supply-psi (see Note 1) | Precharge Inlet Air Range-psi | Outlet Air Range-psi | Port Thread Size | | Size | | | | Weight | | | |
|---------------------------|-----------|-------|-------------------------------------|-------------------------------|----------------------|------------------|------------------|------------|------|-----------|------|-------------|-----|---------------|------|
| Model No. | Ref. No | Ratio | | | | Driving Air | Inlet-Outlet Air | Length in. | cm | Width in. | cm | Actual lbs. | kg | Shipping lbs. | kg |
| S-86-JN-2 | 88734-1 | 2:1 | 25-200 | 25-450 | 50-450 | 1/2 NPT | 3/8 NPT | 18-1/4 | 46.3 | 7-3/4 | 19.6 | 17 | 7.7 | 20 | 9.1 |
| S-86-JN-5 | 88621-1 | 5:1 | 25-200 | 50-1100 | 125-1100 | 1/2 NPT | 3/8 NPT | 18-1/4 | 46.3 | 7-3/4 | 79.6 | 16 | 7.3 | 20 | 9.1 |
| S-86-JN-15 | 90081-1 | 15:1 | 25-200 | 100-3100 | 375-3100 | 1/2 NPT | 1/4 NPT | 17-1/2 | 44.5 | 7-3/4 | 19.6 | 18 | 8.2 | 21 | 9.5 |
| S-86-JN-30 | 88186-101 | 30:1 | 25-200 | 200-6000 | 750-6000 | 1/2 NPT | 1/4 NPT | 15-1/2 | 39.4 | 11-5/8 | 29.5 | 19-1/2 | 8.8 | 22 | 10.0 |
| S-86-JN-60 | 90404-1 | 60:1 | 25-100 | 300-6100 | 1500-6100 | 1/2 NPT | 1/4 NPT | 15-7/8 | 40.3 | 11-5/8 | 29.5 | 19-1/2 | 8.8 | 22 | 10.0 |
| S-86-JN-100 | 90036-2 | 100:1 | 25-100 | 500-10300 (see Note 2) | 2500-10300 | 1/2 NPT | 1/4 NPT | 15-7/8 | 40.3 | 11-5/8 | 29.5 | 19-1/2 | 8.8 | 22 | 10.0 |

Notes: 1. Maximum driving air consumption of the boosters is approximately 80 SCFM @ 100 psi. Boosters will operate with less than 80 SCFM and with less than 100 psi.

2. Minimum precharge of 800 psi is necessary to obtain a maximum output pressure of 10300 psi.

GAS BOOSTER POWER UNITS

Assembled, ready-to-use gas booster power units are suitable for general use or for cleanroom or laboratory use. The power units can be used within portable power supply circuits or stationary pneumatic circuits.

Being air driven, the power units are non-sparking and safe for use in hazardous areas.

The power unit assembly includes an S-86-JN-() type booster, air filter, air pressure regulator, air gauges, driving air shut-off and bleed valves, high pressure manifold fitting and muffler.

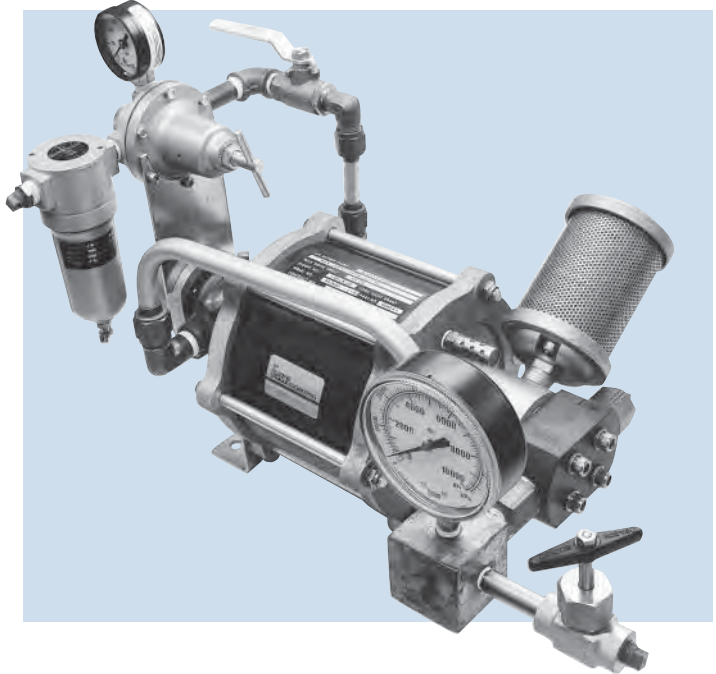

Table 4, S-486-JN GAS BOOSTER POWER UNITS DATA (NOMINAL)

| Gas Booster Power Unit | | Ratio | Gas Booster used in power unit | Port Thread Size | | Length | | Size Width | | Height | | Weight | | | |
|------------------------|----------|-------|--------------------------------|------------------|------------------|--------|------|------------|------|--------|------|-------------|------|---------------|------|
| Model No. | Ref. No. | | | Driving Air | Inlet-Outlet Air | in. | cm | in. | cm | in. | cm | Actual lbs. | kg | Shipping lbs. | kg |
| S-486-JN-2 | 90017-2 | 2:1 | S-86-JN-2 | 3/8 NPT | 3/8 NPT | 23-1/2 | 59.7 | 10-3/4 | 27.3 | 13-1/2 | 34.3 | 27 | 12.2 | 33 | 15.0 |
| S-486-JN-5 | 90017-5 | 5:1 | S-86-JN-5 | 3/8 NPT | 3/8 NPT | 23-1/2 | 59.7 | 10-3/4 | 27.3 | 13-1/2 | 34.3 | 27 | 12.2 | 33 | 15.0 |
| S-486-JN-15 | 90204-1 | 15:1 | S-86-JN-15 | 3/8 NPT | 1/4 NPT | 23-7/8 | 60.6 | 9-1/2 | 24.1 | 13-1/2 | 34.3 | 26-1/4 | 11.9 | 38 | 17.2 |
| S-486-JN-30 | 90018-1 | 30:1 | S-86-JN-30 | 3/8 NPT | 1/4 NPT | 19-7/8 | 50.5 | 10-3/4 | 27.3 | 13-1/2 | 34.3 | 29-3/4 | 13.5 | 37 | 16.8 |
| S-486-JN-60 | 90647-1 | 60:1 | S-86-JN-60 | 3/8 NPT | See Note Below | 20-3/4 | 52.7 | 10-3/4 | 27.3 | 13-1/2 | 34.3 | 30 | 13.6 | 37 | 16.8 |
| S-486-JN-100 | 90153-1 | 100:1 | S-86-JN-100 | 3/8 NPT | See Note Below | 20-3/4 | 52.7 | 10-3/4 | 27.3 | 13-1/2 | 34.3 | 30 | 13.6 | 37 | 16.8 |

Note: Inlet port: 1/4 NPT, Outlet port: 9/16-18UNF-3B (NBS port)



2955 W. 17th Street • Erie, Pennsylvania 16505 U.S.A. • Phone: (814) 838-2028 • 1-800-289-7447
 Fax: (814) 838-6075 • E-Mail: sales@highpressure.com • www.HighPressure.com

© 2017 High Pressure Equipment Company