



Standard Operating & Maintenance Instructions for Pumping Systems

Standard Operating & Maintenance
Instructions for Pumping
Systems -- Models Nos.

PS-10, PS-30, PS-40 & PS-50

High Pressure Equipment Company

P.O. Box 8248, 1222 Linden Avenue Erie, PA 16505 U.S.A. · Phone: (814) 838-2028 · 1-800-289-7447 · Fax: (814) 838-6075



Standard Operating & Maintenance Instructions for Pumping Systems

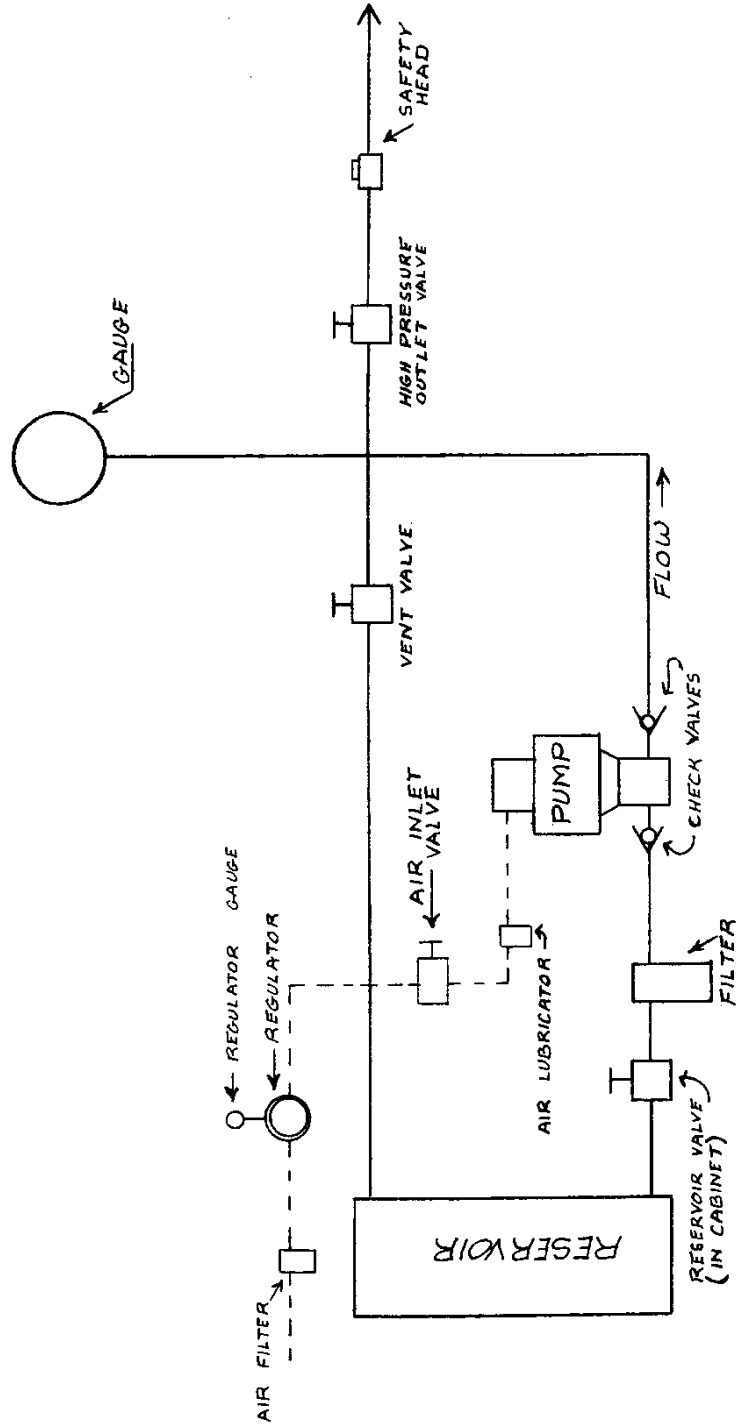

High Pressure Equipment Company



Standard Operating & Maintenance Instructions for Pumping Systems

INSTALLATION

The only connections required for installation of the system are an air supply and connection of the system to the pressure vessel or unit which is to be pressurized.

The air supply line is connected directly to the side of the cabinet and is for 1/2" NPT pipe. A larger air supply line is recommended if the system is quite a distance from the source of air. Pressure of the air supply should be between 70 psi and 150 psi.

The high pressure outlet connection is for 1/4" OD coned and threaded tubing (HF4 connection).

The reservoir is built directly into the cabinet and should be filled with a suitable fluid before operation. Most any low viscosity petroleum base hydraulic oil may be used. Other fluids including water may be used on occasion if it becomes necessary, however, water will decrease the packing life of the pump and should not be used if avoidable.

High Pressure Equipment Company

P.O. Box 8248, 1222 Linden Avenue Erie, PA 16505 U.S.A. · Phone: (814) 838-2028 · 1-800-289-7447 · Fax: (814) 838-6075



Standard Operating & Maintenance Instructions for Pumping Systems

OPERATION

- 1) Set the air regulator at the desired pressure range in accordance with the regulator setting chart. This is indicated on the small air regulator gauge on the face of the cabinet.
- 2) Close the "Vent Valve".
- 3) Open the "High Pressure Outlet Valve".
- 4) Open the "Air Supply Valve".

The system will now begin to build up pressure until the set pressure limit is reached and then will automatically stop. Should there be any pressure loss due to temperature, compaction of the materials being pressurized, or leakage in the item being pressurized, the pump will automatically start up and compensate for the pressure loss.

High Pressure Equipment Company

P.O. Box 8248, 1222 Linden Avenue Erie, PA 16505 U.S.A. · Phone: (814) 838-2028 · 1-800-289-7447 · Fax: (814) 838-6075



Standard Operating & Maintenance Instructions for Pumping Systems

VENTING THE PRESSURE

To vent the pressure from the system simply shut off the "Air Inlet Valve" and open the "Vent Valve" and all of the pressurized fluid will return to the reservoir.

Pressure may be vented rapidly or slowly by simply controlling the amount the vent valve is opened.

High Pressure Equipment Company

P.O. Box 8248, 1222 Linden Avenue Erie, PA 16505 U.S.A. · Phone: (814) 838-2028 · 1-800-289-7447 · Fax: (814) 838-6075



Standard Operating & Maintenance Instructions for Pumping Systems

SAFETY FEATURES

The system includes a safety head and rupture disc located within the cabinet in order to provide maximum safety to the operator. The disc has been installed at the factory and is rated slightly higher than the maximum working pressure of the unit. In the event the pressure is permitted to exceed the maximum working pressure, the disc will rupture before any damage of the gauge or other components occurs. The safety head is machined with a pipe thread on the exhaust. A pipe connection may be run from this opening to any convenient vent. This will eliminate any oil spillage within the cabinet in the event the disc becomes ruptured.

High Pressure Equipment Company

P.O. Box 8248, 1222 Linden Avenue Erie, PA 16505 U.S.A. · Phone: (814) 838-2028 · 1-800-289-7447 · Fax: (814) 838-6075



Standard Operating & Maintenance Instructions for Pumping Systems

VALVES

It is not necessary to close the high pressure valves extremely tight for maximum shutoff. This will tend to damage the valve seat and the stem.

High Pressure Equipment Company

P.O. Box 8248, 1222 Linden Avenue Erie, PA 16505 U.S.A. · Phone: (814) 838-2028 · 1-800-289-7447 · Fax: (814) 838-6075



Standard Operating & Maintenance Instructions for Pumping Systems

MAINTENANCE

The air line is equipped with a filter and lubricator. The air filter is provided to filter water from the air supply. Depending upon the amount of water in your air supply, the filter bowl will fill up over a period of time. This is easily drained by opening the small drain cock on the bottom of the bowl and allowing the water to drain into a container.

The lubricator is provided in order to lubricate the air portion of the pump. This has been set at the factory for typical air flow conditions. An oil flow of approximately 3 to 5 drops per minute is recommended. This lubricator should be periodically checked and filled with a lubricating oil of approximately 150 to 200 S.S.U. @ 100°F (S.A.E. 10).

The fluid within the reservoir should be kept clean in order to provide maximum life of the pump. When this fluid becomes excessively dirty, it is easily drained through the drain plug located at the bottom of the reservoir. A filter is provided between the reservoir and the pump. It is recommended that the disposable cartridge be removed and replaced should it become clogged with an excess of dirt. The valve between the reservoir and filter should be closed before removing the filter.

High Pressure Equipment Company

P.O. Box 8248, 1222 Linden Avenue Erie, PA 16505 U.S.A. · Phone: (814) 838-2028 · 1-800-289-7447 · Fax: (814) 838-6075



Standard Operating & Maintenance Instructions for Pumping Systems

TROUBLE SHOOTING

The pump is running but will not develop pressure:

- 1) If the system has just been shipped, moved to a new location or repairs have been made within the hydraulic lines, an "air lock" may have developed. A connection on the inlet side of the pump should be broken enough to determine whether or not the pump is receiving oil from the reservoir. If so, a connection on the outlet side of the pump should be broken slightly. With the pump operating (set the regulator so that the pump is operating slowly) determine as to whether there is a flow through the lines. This will usually clear the "air lock" and the connection can be retightened.

- 2) If the pump will not develop pressure and there does not appear to be an "air lock", the check valves on the inlet and outlet side of the pump should be cleaned or replaced.

High Pressure Equipment Company

P.O. Box 8248, 1222 Linden Avenue Erie, PA 16505 U.S.A. · Phone: (814) 838-2028 · 1-800-289-7447 · Fax: (814) 838-6075



Standard Operating & Maintenance Instructions for Pumping Systems

SPARE PARTS

Spare parts or further information about your pumping system may be obtained direct from the factory. Parts are generally stocked for immediate delivery.

HIGH PRESSURE EQUIPMENT CO. INC.
1222 LINDEN AVENUE
ERIE, PENNSYLVANIA, U.S.A. (16505)

AREA CODE 814 PHONE: 838-2028

High Pressure Equipment Company

P.O. Box 8248, 1222 Linden Avenue Erie, PA 16505 U.S.A. · Phone: (814) 838-2028 · 1-800-289-7447 · Fax: (814) 838-6075



Standard Operating & Maintenance Instructions for Pumping Systems

NIP-6e

INSTRUCTIONS and PARTS LIST PRESSURE REGULATOR Type 11-002

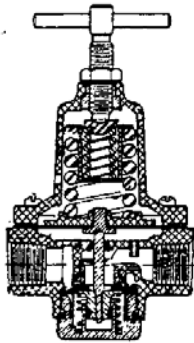

INSTALLATION

Install the regulator as near as possible to the device it is to serve, downstream from the filter, but upstream from the lubricator. Note the arrow stamped onto the body which indicates direction of air flow. Use pipes and fittings large enough to allow unrestricted air flow through the regulator.

OPERATION

Before turning on the air pressure, turn out the adjusting screw (1) relieving compression on the regulating spring (7a) thus closing the valve. After the air pressure is turned on, turn the adjusting screw (1) in until the secondary pressure gauge shows the desired pressure. It is best to adjust the regulator under typical flow conditions.

MAINTENANCE

To prevent foreign material from the pipe line from entering the valve the regulator has a strainer screen (16). This should be cleaned regularly. The screen is removed by unscrewing the bottom plug (19).

The regulator can be disassembled for servicing without removing it from the pipe line. To disassemble shut off the air pressure and turn out the adjusting screw (1) to relieve all compression on the spring (7a). Remove the bonnet screws (4) to take off the bonnet (3), the upper spring rest (5), the intermediate spring rest (6), the springs (7a), and the diaphragm assembly (8, 9 & 10). To disassemble the diaphragm assembly grasp the lower spring rest (8) firmly in one hand and with a wrench unscrew the diaphragm screw (10) or relief seat (11).

The valve (14) will come out when the bottom plug (19) is removed. The screen (16) can then also be taken out.

Clean and inspect each part carefully. If any part is damaged, replace it, ordering from the parts list on reverse side. When assembling put a coat of grease onto the "O" ring on the valve (14). Assemble with the regulator in a vertical position.

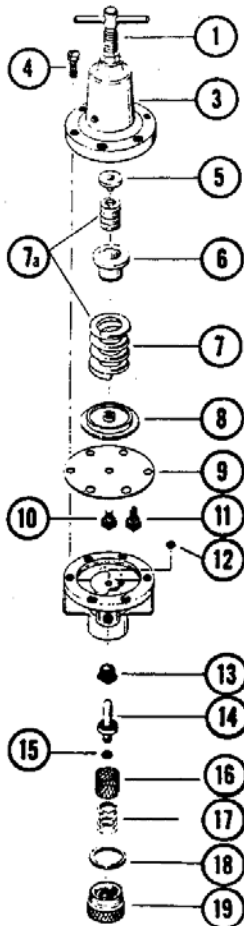

first name in pneumatic products



C. A. NORGRÉN CO.
5400 SOUTH DELAWARE
LITTLETON, COLORADO

World's largest manufacturer of pneumatic filters, regulators, lubricators and air control valves. Write for free catalog.

High Pressure Equipment Company

P.O. Box 8248, 1222 Linden Avenue Erie, PA 16505 U.S.A. • Phone: (814) 838-2028 • 1-800-289-7447 • Fax: (814) 838-6075



Standard Operating & Maintenance Instructions for Pumping Systems

PRESSURE REGULATOR Type 11-002

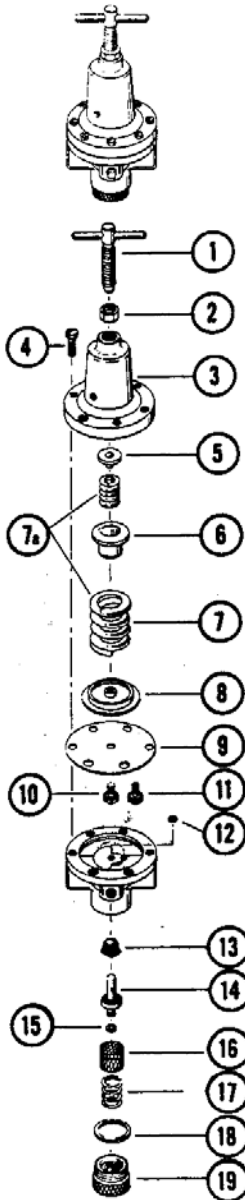

Parts List

REPAIR KITS	Pipe Size	1/4", 3/8"	1/2"	3/4", 1"	
1/4" and 3/8" non-relieving		529-01			\$2.00
1/4" and 3/8" relieving		529-03			2.20
1/2" non-relieving			535-01		1.85
1/2" relieving			535-03		2.25
3/4" and 1" non-relieving				536-01	2.95
3/4" and 1" relieving				536-03	3.40

Kits contain:

9. Diaphragm	481-01	481-01	482-01	
12. "O" ring	705-01	705-01	705-01	
14. Valve (includes "O" ring #15)	496-03	497-03	498-05	
16. Strainer screen	509-01	510-01	511-01	
17. Valve spring	506-01	507-01	508-01	
18. "O" ring for plug	918-01	522-01	523-01	

REPLACEMENT PARTS

1. Adjusting screw	1094-03	1094-03	-	.55
Adjusting screw	-	-	1095-03	.75
2. Lock nut	1305-01	1305-01	1363-01	.05
4. Screws (set)	1317-02	1317-02	-	.06
Screws (set)	-	-	66-02	.10
5. Upper spring rest, 50 psig	1288-01	1288-01	-	.20
50 psig	-	-	1324-01	1.50
125 psig	477-01	477-01	-	.20
125 psig	-	-	478-01	.35
250 psig	1290-01	1290-01	-	.35
6. Intermediate Spring rest				
125 psig	524-01	524-01	-	.35
125 psig	-	-	525-01	.40
7. Regulating spring, 50 psig	499-01	499-01	-	.25
50 psig	-	-	500-01	.80
250 psig	501-01	501-01	-	.60
7a. Compound spring, 125 psig	502-02	502-02	-	.50
125 psig	-	-	503-02	1.00
8. Lower spring rest	479-02	479-02	-	.65
Lower spring rest	-	-	480-02	1.15
10. Seat (non-relieving type)	520-01	520-01	520-01	
13. Valve seat	483-01	-	-	.25
Valve seat	-	484-01	-	.30
Valve seat	-	-	485-01	.70
19. Valve guide plug	512-02	-	-	.95
Valve guide plug	-	513-02	-	1.60
Valve guide plug	-	-	514-02	4.00

PARTS NOT NORMALLY REPLACED

3. Bonnet	470-02	470-02	472-02	
Body				

NIP-6e/60M/ 66/N
Printed in U.S.A.

Terms: 30 days net. Prices subject to change without notice.
These prices are not good outside of the United States



C.A. Norgren Co./5400 South Delaware/Littleton, Colorado

High Pressure Equipment Company

P.O. Box 8248, 1222 Linden Avenue Erie, PA 16505 U.S.A. · Phone: (814) 838-2028 · 1-800-289-7447 · Fax: (814) 838-6075



Standard Operating & Maintenance Instructions for Pumping Systems

NIP-9c

INSTRUCTIONS and PARTS LIST MANUAL DRAIN FILTER Type 12-002

PIPE SIZES 1/4", 3/8", 1/2"

INSTALLATION

Install the filter ahead of the regulator and lubricator in the compressed air line, as near as possible to the machine or device it is to serve. Note the arrow on the body which indicates the direction of air flow through the filter. Do not use the plastic bowl on air systems using synthetic, fire-resistant lubricants in the air compressor.

OPERATION

It is important to drain the bowl regularly. Never permit moisture to fill the bowl above the baffle (4).

The maximum temperature and pressure for this filter is 100° F. at 250 psig, 160° F. at 200 psig, or 200° F. at 100 psig.

MAINTENANCE

For cleaning and service the filter must be disassembled. To do this, first shut off the air pressure then disassemble. Remove the clamp ring (5) and unscrew the baffle (4). This will release the filter element (3).

Clean the filter element (3) in a cleaning solvent and blow it out with compressed air. It is important to keep this filter element (3) clean.

When cleaning the parts use soap and water or a petroleum solvent such as kerosene.

CAUTION: The plastic parts used in this product will be damaged by acetone, methyl alcohol, benzene, dioxane, ethyl acetate, lacquer thinners, toluene, carbon tetrachloride and other aromatic hydrocarbons, chlorinated hydrocarbons or strong alkaline substances.

Before reassembly clean and check each part thoroughly. If any are damaged replace them, ordering from the Parts List.

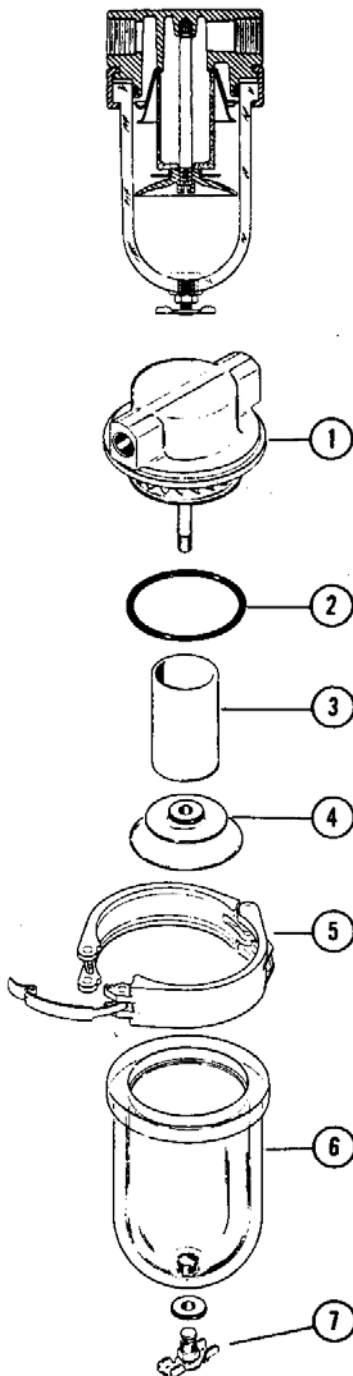

NIP-9c/40M/1-67/N
Printed in U.S.A.

REPLACEMENT PARTS

2. "O" ring	2317-26	\$.20
3. Filter element		
75-micron Monel screen	730-01	1.90
50-micron sintered bronze	723-01	1.90
25-micron sintered bronze	723-02	1.90
5-micron sintered bronze	723-03	2.90
4. Baffle	787-01	.30
5. Clamp-ring assembly	788-02	1.80
6. Bowl (with drain-cock)		
Safety-Green	603-18	2.80
Metal	601-14	4.10
7. Drain-cock	684-01	.15
* Bowl insert gasket (not shown)	2811-01	.05

PARTS NOT NORMALLY REPLACED

1. Body - 1/4" pipe size	789-02
- 3/8" pipe size	790-03
- 1/2" pipe size	790-04

Terms: 30 days net. Prices subject to change without notice.
These prices are not good outside of the United States

first name in pneumatic products



C. A. NORGREN CO.
5400 SOUTH DELAWARE
LITTLETON, COLORADO

World's largest manufacturer of pneumatic filters, regulators, lubricators and air control valves. Write for free catalog.

High Pressure Equipment Company

P.O. Box 8248, 1222 Linden Avenue Erie, PA 16505 U.S.A. · Phone: (814) 838-2028 · 1-800-289-7447 · Fax: (814) 838-6075



Standard Operating & Maintenance Instructions for Pumping Systems

Instructions for Installation and Operation of

NI 3002

Oil-Fog Lubricators

INSTALLATION

Install the lubricator downstream from the filter and regulator as near as possible to the device it is to serve.

Lubricators 10-002, 10-003 and 10-053 are reversible and can be installed with the air flow in either direction. Arrows on the venturi tube can be seen through the sight-feed glass and must point in the direction of air flow. To change the direction of flow remove the needle valve assembly (1), and the drip gland (2), and adjust the venturi tube (3) with a screwdriver.

The 10-076 must be installed with air flowing in the direction indicated by the arrow on the lubricator body.

WARNING: Do not use the transparent bowl on air systems using synthetic, fire-resistant lubricants in the air compressor. These lubricants attack and may cause failure of the polycarbonate bowl. For applications which require the use of fire resistant compressor oils, equip the lubricator with a metal bowl.

LUBRICANTS: Fill the lubricator with oil through the filler plug. Use high quality lubricating oil of approximately 150 to 200 S.S.U. at 100° F. (S.A.E. 10). Do not use oils containing graphites, soap, fillers, etc. The lubricator reservoir may be filled without turning off air pressure.

OPERATION

Maximum recommended operating pressures and temperatures for transparent bowls are 250 psig at 120° F. ambient, 200 psig at 160° F. ambient, or 100 psig at 175° F. ambient; and for metal reservoirs 250 psig at 175° F. ambient.

To start the lubricator, close the needle valve completely. After the air is turned on, open the needle valve and adjust under typical flow conditions. Usually 3 to 5 drops per minute is sufficient.

The felt throttling disc (4) in the 10-002, 10-003 and 10-053 provides accuracy of oil feed adjustment at low rates of flow (1-15 drops/minute). At higher rates of flow this filter disc may restrict the flow; if it does it should be removed.

LUBRICATOR ADJUSTMENTS

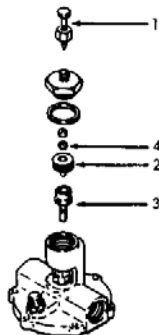

CAUTION

The transparent bowl will be damaged by the following materials:

COMPRESSOR OILS

Cellulube #150 and #220
Kano Krail

Keystone penetrating oil #2
Pydraul AC

OTHER MATERIALS

Acetaldehyde
Acetic acid (conc.)
Acetone
Acrylonitrile
Ammonium fluoride
Ammonium sulfide
Benzene
Benzoic acid
Benzyl alcohol
Bromobenzene
Butyric acid
Carbolic acid
Carbon disulfide
Carbon tetrachloride
Caustic potash solution (5%)
Caustic soda solution (5%)
Chlorobenzene
Chloroform
Cresol
Cyclohexanol
Cyclohexanone
Cyclohexene
Dimethyl formamide
Dioxane
Ethane tetrachloride
Ethyl ether
Ethylamine

Ethylene chlorohydrin
Ethylene dichloride
Formic acid (conc.)
Freon (Du Pont trademark)
Gasoline (high aromatic)
Hydrochloric acid (conc.)
Methyl alcohol
Methylene chloride
Milk of lime (CaOH)
Nitric acid (conc.)
Nitrobenzene
Nitrocellulose lacquer
Phenol
Phosphorous hydroxy chloride
Phosphorous trichloride
Propionic acid
Pyridine
Sodium sulfide
Styrene
Sulfuric acid (conc.)
Sulphural chloride
Tannergas
Tetrahydronaphthalene
Thiophene
Toluene
Xylene

When cleaning parts use only soap and water or a petroleum solvent such as kerosene.



10M/3-67

Printed in U.S.A.

High Pressure Equipment Company

P.O. Box 8248, 1222 Linden Avenue Erie, PA 16505 U.S.A. • Phone: (814) 838-2028 • 1-800-289-7447 • Fax: (814) 838-6075